

## Product Specifications Sheets



Model No.	Description	Length	Depth	Height	Voltage	Amps	HP/BTUs	Power Cord	Est. Ship Weight
<b>SC-CDS34E-4</b>	Self Contained	52.5"	36.5"	53.5"	115	6.0	1/4	NO	530
<b>SC-CDS34E-6</b>	Self Contained	76.5"	34.5"	53.5"	115	8.7	1/3	NO	741
<b>SC-CDS34E-8</b>	Self Contained	100.5"	34.5"	53.5"	115	11.2	1/2	NO	897
<b>SC-CDS34E-10</b>	Self Contained	124.5"	34.5"	53.5"	115	13.8	1/2	NO	1150
<b>SC-CDS34E-12</b>	Self Contained	148.5"	34.5"	53.5"	115	17.4	3/4	NO	1414
<b>R-CDS34E-4</b>	Remote	52.5"	34.5"	53.5"	115	0.8	1400	NO	497
<b>R-CDS34E-6</b>	Remote	76.5"	34.5"	53.5"	115	1.3	2100	NO	693
<b>R-CDS34E-8</b>	Remote	100.5"	34.5"	53.5"	115	1.6	2800	NO	832
<b>R-CDS34E-10</b>	Remote	124.5"	34.5"	53.5"	115	2.4	3500	NO	1089
<b>R-CDS34E-12</b>	Remote	148.5"	34.5"	53.5"	115	2.4	4200	NO	1359

MODEL NUMBER SUFFIX - B = Black W = White SS = Stainless Steel  
 • Cases are designed to operate at 75 degrees Fahrenheit and 55% relative humidity  
 • Specification subject to change without notice



## Standard Specifications and Optional Features

### CONSTRUCTION

- UL Classified to ANSI/NSF 7
- Foamed in place CFC free foam
- Triple pane insulated front glass - 28" H
- Heavy gauge steel super structure
- Bottom storage
- Endless design allows for continuous line up
- Drain is included for cleaning

### INTERIOR

- White, black, and stainless steel ends
- Stainless steel heavy gauge mezzanine shelf
- White aluminum floor (bottom storage area)
- Air insulated baffle (prevents moisture from dripping into display area)

### EXTERIOR

- Double pane rear removable doors
- Newly designed rear compression door jamb
- Removable front grille allows for cleaning
- Removable rear grille for easy servicing
- 2 - 1/4" removeable end panels

### FINISHES

- Satin finish extrusion on doors and door tracks
- White, black, and stainless steel front and ends
- Stainless steel mirror trim
- Stainless steel heavy gauge top - 19 - 1/2" W
- White exterior rear

### LIGHTING

- 2 rows of T12 lighting at top of unit

### ELECTRICAL REQUIREMENTS

- 115V
- Unit must be hard wired
- UL/CUL listed
- 115V-12AMP general purpose receptacle (wired separately)

### REFRIGERATION

- Coevap system (eliminates need for condensate pan)
- R134A expansion valve system
- Gravity coil located at inside top of unit
- Self contained unit
- Automatic defrost controlled by time clock (self contained unit only)
- Pressure control maintains constant temperatures
- Remotes available

### OPTIONS

- LED lit
- LED lit shelves
- Scale stand
- Paper cutter
- Stainless steel, laminate, or paint
- Mirrored doors
- Extra stainless steel mezzanine shelf
- Drop work shelf
- Front bumper 1" or 3"
- Door lock
- Digital thermometer
- Pass thru front doors
- Sandwich racks
- Salad pan settings

### **Important Note:**

**All refrigerated cases are designed to operate in an environment of 75 degrees and 55% relative humidity.**

**Product must be cooled before being displayed within the case.**

**DRAIN IS REQUIRED**



**Technical Data**

Model No.	SC R	SC-CDS34E-4 R-CDS34E-4	SC-CDS34E-6 R-CDS34E-6	SC-CDS34E-8 R-CDS34E-8	SC-CDS34E-10 R-CDS34E-10	SC-CDS34E-12 R-CDS34E-12
Length with (2) ends		52.5"	76.5"	100.5"	124.5"	148.5"
Length without ends		48"	72"	96"	120"	144"
Height with ends		53.5"	53.5"	53.5"	53.5"	53.5"
Height without ends		53"	53"	53"	53"	53"
Depth with ends		37.5"	34.5"	34.5"	34.5"	34.5"
Depth without ends		37"	34"	34"	34"	34"
Endless design		YES	YES	YES	YES	YES
(Dimensions are +/- 1/4")						
Operating temperature		36°F to 40°F	36°F to 40°F	36°F to 40°F	36°F to 40°F	36°F to 40°F
Refrigerant (exp. valve)	SC	R134A	R134A	R134A	R134A	R134A
Compressor size HP	SC	1/4	1/3	1/2	1/2	3/4
Defrost per day (24 hours)	Air Defrost	1 per day	1 per day	1 per day	1 per day	1 per day
BTU's at +20°F Evap. Temp.	R	1400	2100	2800	3500	4200
Voltage	SC	115	115	115	115	115
Amperage	SC	6.0	8.7	11.2	13.8	17.4
Remote Voltage	R	115	115	115	115	115
Amperage, lights only	R	0.8	1.3	1.6	2.4	2.4
Cord and plug	SC	NO	NO	NO	NO	NO
	R	NO	NO	NO	NO	NO
Exterior color		W, B, SS	W, B, SS	W, B, SS	W, B, SS	W, B, SS
Interior color		W, B, SS	W, B, SS	W, B, SS	W, B, SS	W, B, SS
Inside end panels		W, B, SS	W, B, SS	W, B, SS	W, B, SS	W, B, SS
Floors		W, B, SS	W, B, SS	W, B, SS	W, B, SS	W, B, SS
# of top doors		2	2	4	4	4
Door size		20.5" x 23.5"	20.5" x 23.5"	20.5" x 23.5"	20.5" x 23.5"	20.5" x 23.5"
# of coils		1	1	1	1	1
Bottom storage		Yes	Yes	Yes	Yes	Yes
Front glass		28" x 46.6875"	28" x 70.6875"	28" x 94.6875"	28" x 118.6875"	28" x 142.6875"
# of main deck shelves		2	3	4	5	6
Main deck size		24" x 28.625"	24" x 28.625"	24" x 28.625"	24" x 28.625"	24" x 28.625"
Cubic capacity		30	45	60	75	90
Mezzanine - shelf		Standard	Standard	Standard	Standard	Standard
<b>Shipping Info</b>						
Height		58"	58"	58"	58"	58"
Depth		44"	44"	44"	44"	44"
Length		61"	87"	109"	135"	157"
Gross weight SC/R		530/497	741/693	897/832	1150/1089	1414/1359
Cubic feet		89	128	164	199	231



**Technical Data • Side View • Plan View**

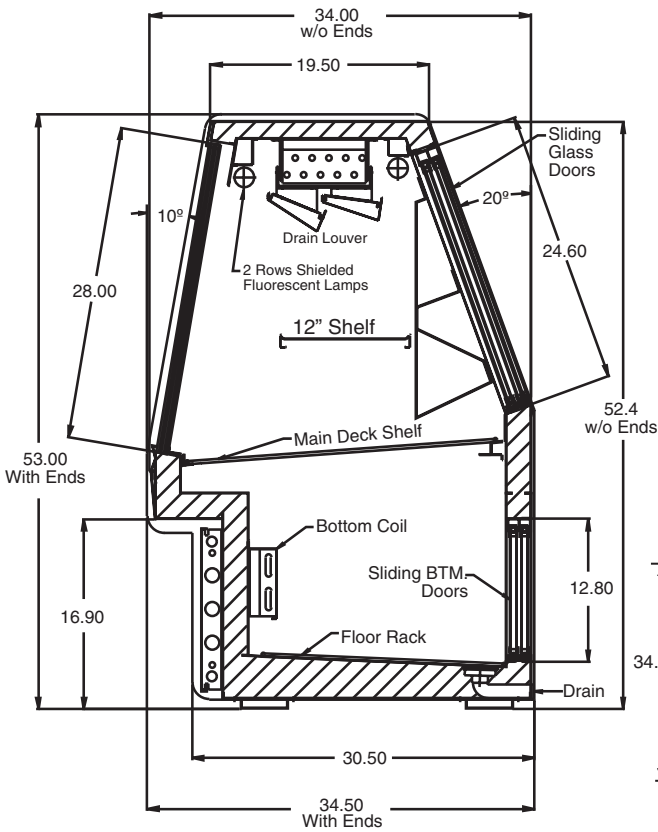

**Cross Section**

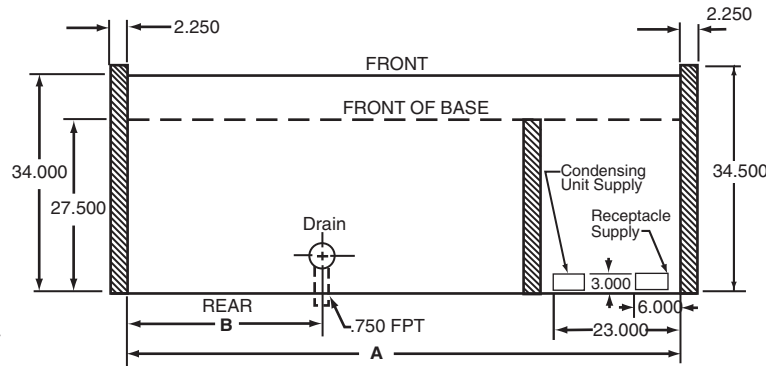

MODEL NO.	A	B
S/C-34E-4	48"	12"
S/C-34E-6	72"	24"
S/C-34E-8	96"	36"
S/C-34E-10	120"	48"
S/C-34E-12	144"	60"

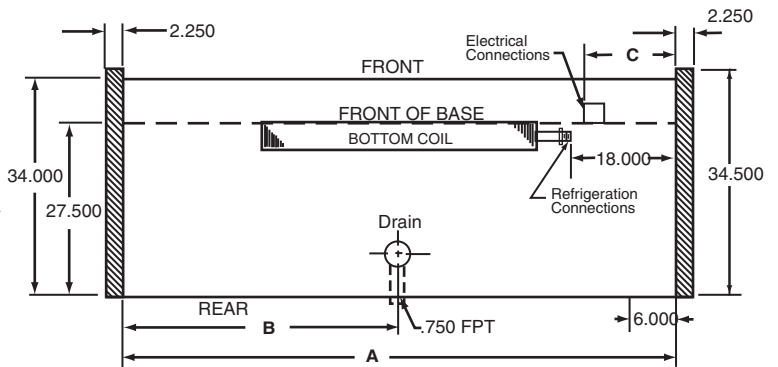

MODEL NO.	A	B	C
R-34E-4	48"	24"	4"
R-34E-6	72"	36"	4"
R-34E-8	96"	48"	52"
R-34E-10	120"	60"	52"
R-34E-12	144"	72"	76"

**Plan Views**

