

Product Specifications Sheets



Model No.	Description	Length	Depth	Height	Voltage	Amps	HP/BTUs	Power Cord	Est. Ship Weight
SC-OD30E-3-LS	Self Contained	39"	30"	72"	115	12.0	1/2	5-15P	535
SC-OD30E-4-LS	Self Contained	51"	30"	72"	115	13.7	1/2	5-20P	615
SC-OD30E-5-LS	Self Contained	63"	30"	72"	115/208-230	13.1	3/4	L14-20P	738
SC-OD30E-6-LS	Self Contained	75"	30"	72"	115/208-230	13.1	3/4	L14-20P	860
SC-OD30E-8-LS	Self Contained	99"	30"	72"	115/208-230	14.3	1	L14-20P	1085
R-OD30E-3-LS	Remote	39"	30"	72"	115	1.4	3900	NO	482
R-OD30E-4-LS	Remote	51"	30"	72"	115	2.2	5200	NO	554
R-OD30E-5-LS	Remote	63"	30"	72"	115	2.8	6500	NO	664
R-OD30E-6-LS	Remote	75"	30"	72"	115	2.8	7800	NO	774
R-OD30E-8-LS	Remote	99"	30"	72"	115	4.3	8320	NO	977
R-OD30E-10-LS	Remote	123"	30"	72"	115	7.0	10400	NO	1328
R-OD30E-12-LS	Remote	147"	30"	72"	115	8.0	12480	NO	1548

MODEL NUMBER SUFFIX - B = Black W = White SS = Stainless Steel

- Cases are designed to operate at 75 degrees Fahrenheit and 55% relative humidity
- Specification subject to change without notice



A Division of HMC Enterprises LLC • 831 East Cayuga St • Philadelphia, PA 19124 USA

(215) 464-6800 • 1-800-344-8222 • Fax (215) 969-4890 • E-Mail: sales@howardmccray.com • www.howardmccray.com

Standard Specifications and Optional Features

CONSTRUCTION

- UL Classified to ANSI/NSF 7
- Foamed in place CFC free foam
- Heavy gauge steel super structure
- Multi deck
- Endless design allows for continuous line up

INTERIOR

- White, black, or stainless steel end panels
- Removable white, black, or stainless steel floor pans
- White, black, or stainless steel perforated rear wall (for even air distribution)
- Full length lighting at top of unit
- 3 levels of lit shelving with product stop
- 4 levels of product display
- Stylish tag molding on each shelf

EXTERIOR

- White, black, or stainless steel ends and front
- White, black, or stainless steel color band
- Removeable front grill allows for cleaning and servicing
- 1" bumper
- Choice of end panels

FINISHES

- White, black, or stainless steel end panels
- White, black, or stainless steel front rail
- White, black, or stainless steel front color band
- White, black, or stainless steel end trim
- Laminate, and custom paints available
- Coated galvanized rear

LIGHTING

- 1 row at inside top of unit
- 3 rows of lighted shelving

ELECTRICAL REQUIREMENTS

- Unit comes with cord and plug
- UL/CUL listed
- See Tech page for details on voltage

REFRIGERATION

- R404A expansion valve system
- Low velocity fans located below deck area (to insure even flow of air)
- Electronic Control System with automatic air defrost to Maintain Balanced Temperatures
- New high efficiency air screen technology
- Self contained system
- Copeland hermetic unit
- Remotes available

OPTIONAL FEATURES

- LED lights
- Night covers
- Security cover
- Peg bars
- Electric condensate pan, with separate plug
- Insulated divider for line ups
- Plexiglas divider for line ups
- Colored bumper
- Stainless steel, laminated or paint
- Product stops on shelving
- 3 Different end panel choices
- Digital thermometer

Important Note:

All refrigerated cases are designed to operate in an environment of 75 degrees and 55% relative humidity. Product must be cooled before being displayed within the case.

DRAIN IS REQUIRED

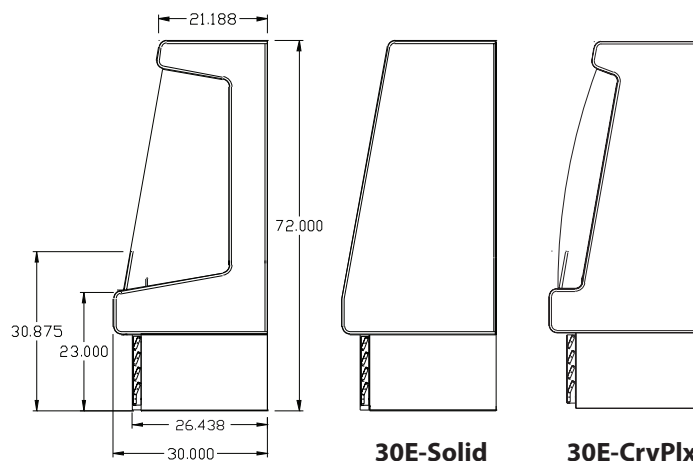

Technical Data

Model No.	SC R	SC-OD30E-3-LS R-OD30E-3-LS	SC-OD30E-4-LS R-OD30E-4-LS	SC-OD30E-5-LS R-OD30E-5-LS	SC-OD30E-6-LS R-OD30E-6-LS	SC-OD30E-8-LS R-OD30E-8-LS	R-OD30E-10-LS	R-OD30E-12-LS
Length with (2) ends		39"	51"	63"	75"	99"	123"	147"
Length without ends		36"	48"	60"	72"	96"	120"	144"
Height with ends		72"	72"	72"	72"	72"	72"	72"
Height without ends		71.5"	71.5"	71.5"	71.5"	71.5"	71.5"	71.5"
Depth with ends		30"	30"	30"	30"	30"	30"	30"
Depth without ends		29"	29"	29"	29"	29"	29"	29"
Endless design		YES	YES	YES	YES	YES	YES	YES
(Dimensions are +/- 1/4")								
Operating temperature		36°F to 40°F	36°F to 40°F	36°F to 40°F	36°F to 40°F	36°F to 40°F	36°F to 40°F	36°F to 40°F
Refrigerant (expansion valve)	SC	R404A	R404A	R404A	R404A	R404A	R404A	R404A
Compressor size HP	SC	1/2	1/2	1	1	1		
Defrost per day (24 hrs) (24 hrs)	Air Defrost	3 @ 30 min.	3 @ 30 min.	3 @ 30 min.	3 @ 30 min.	3 @ 30 min.	3 @ 30 min.	3 @ 30 min.
BTU's at +20°F Evap. Temp.	R	3900	5200	6500	7800	8320	10400	12480
Voltage	SC	115	115	115/208-230	115/208-230	115/208-230		
Amperage	SC	12	13.7	13.1	13.1	14.3		
Remote Voltage	R	115	115	115	115	115	115	115
Amperage, lights only	R	1.4	2.2	2.8	2.8	4.3	7.0	8.0
Cord and plug	SC	5-15P	5-20P	L14-20P	L14-20P	L14-20P		
	R	NO	NO	NO	NO	NO	NO	NO
Exterior color		W, B, SS	W, B, SS	W, B, SS	W, B, SS	W, B, SS	W, B, SS	W, B, SS
Interior color		W, B, SS	W, B, SS	W, B, SS	W, B, SS	W, B, SS	W, B, SS	W, B, SS
# of shelves		3	3	3	3	3	3	3
Shelf size depth		(1) 14" (1) 16"	(1) 14" (1) 16"	(2) 14" (2) 16"	Call for Info	Call for Info	Call for Info	Call for Info
Shipping Info								
Height		76"	76"	76"	76"	76"	76"	76"
Depth		44"	44"	44"	44"	44"	44"	44"
Length		61"	61"	Call for Info	87"	109"	Call for Info	Call for Info
Gross weight SC/R		535	615	Call for Info	860	1085	Call for Info	Call for Info
Cubic feet		115	115	Call for Info	166	206	Call for Info	Call for Info

(ALL WHITE OR ALL BLACK, NO EXTRA CHARGE—IF COLORS ARE MIXED AN ADDITIONAL CHARGE WILL APPLY)

Prefix

SC = Self Contained
R = Remote

Suffix

B = Black
W = White
SS = Stainless Steel
LS = T8 lighting
LED = LED lighting

- Cases are designed to operate at 75 degrees Fahrenheit and 55% relative humidity
- Cases are equipped with drains; check your local building codes for connection requirements.
- Specification subject to change without notice



A Division of HMC Enterprises LLC • 831 East Cayuga St • Philadelphia, PA 19124 USA

(215) 464-6800 • 1-800-344-8222 • Fax (215) 969-4890 • E-Mail: sales@howardmccray.com • www.howardmccray.com

Technical Data • Side View • Plan View

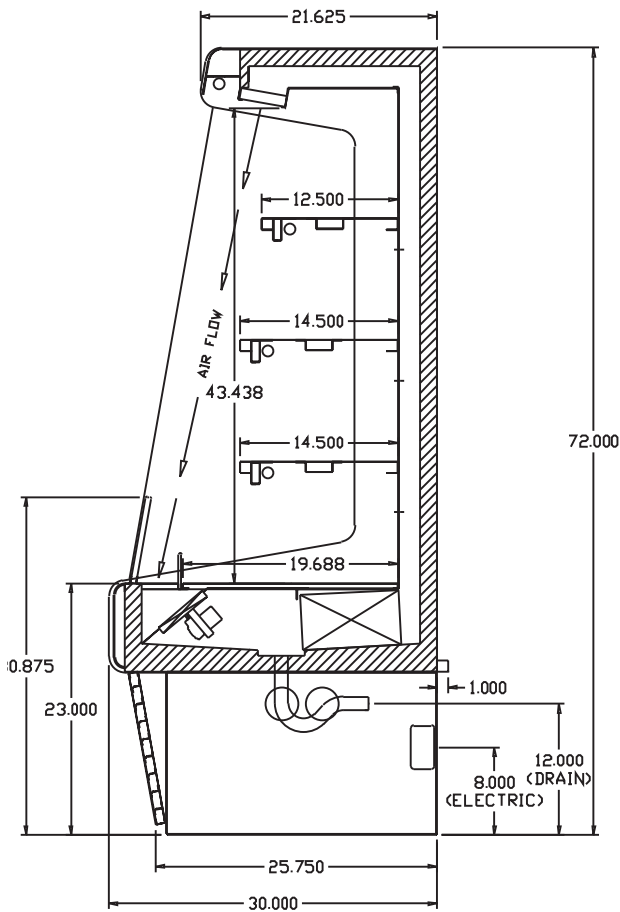

Cross Section

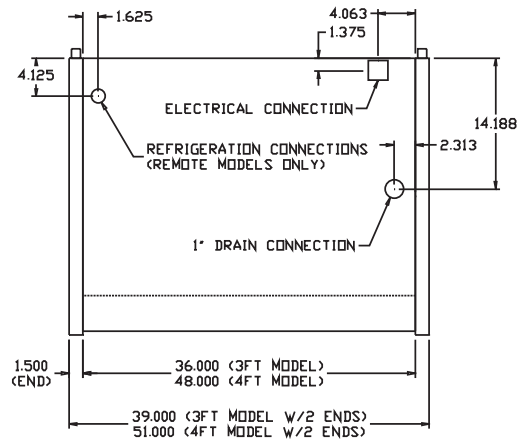
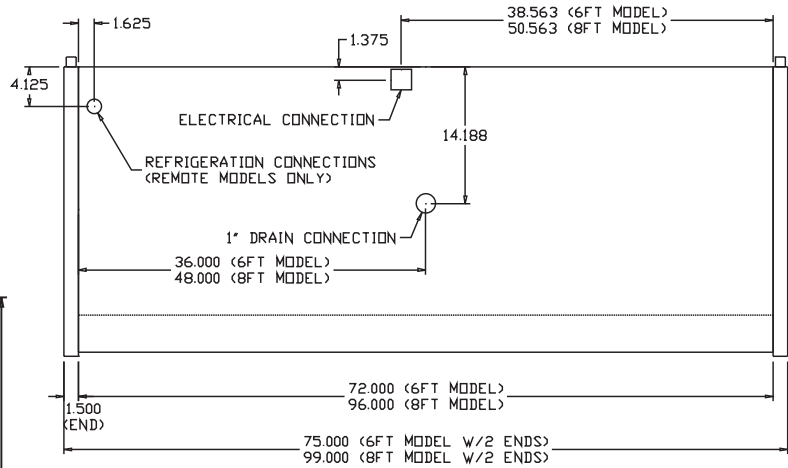

Plan View

