

### Product Specification Sheet



Model No.	Description	Length	Depth	Height W/Casters	Voltage	Amps	HP/BTUs	Power Cord	Est. Ship Weight
<b>Refrigerators</b>									
<b>SR22</b>	One Door	26.50"	35.38"	83.00"	115	6.8	1/4	5-15P	328
<b>SR48</b>	Two Door	52.25"	35.38"	83.00"	115	9.6	1/3	5-15P	516
<b>SR75</b>	Three Door	78.00"	35.38"	83.00"	115	12.1	1/2	5-20P	720
<b>R-SR22</b>	One Door	26.50"	35.38"	83.00"	115	1.1	1740BTUs	NO	328
<b>R-SR48</b>	Two Door	52.25"	35.38"	83.00"	115	2.0	2300BTUs	NO	516
<b>R-SR75</b>	Three Door	78.00"	35.38"	83.00"	115	2.3	4400 BTUs	NO	720
<b>Freezers / Frozen Food</b>									
<b>SF22-FF</b>	One Door	26.50"	35.38"	83.00"	115	12.0	1/2	5-15P	373
<b>SF48-FF</b>	Two Door	52.25"	35.38"	83.00"	115	16.0	1/2	5-20P	710
<b>SF75-FF</b>	Three Door	78.00"	35.38"	83.00"	115/208-230	16.0	3/4	L14-20P	790
<b>R-SF22-FF</b>	One Door	26.50"	35.38"	83.00"	115	9.6	1556 BTUs	NO	328
<b>R-SF48-FF</b>	Two Door	52.25"	35.38"	83.00"	115	14.0	2100 BTUs	NO	516
<b>R-SF75-FF</b>	Three Door	78.00"	35.38"	83.00"	115/208-230	8.6	3400 BTUs	NO	720
<b>Freezers / Low Temp</b>									
<b>SF22-LT</b>	One Door	26.50"	35.38"	83.00"	115	12.0	1/2	5-15P	373
<b>SF48-LT</b>	Two Door	52.25"	35.38"	83.00"	115	16.0	3/4	5-20P	710
<b>SF75-LT</b>	Three Door	78.00"	35.38"	83.00"	115/208-230	16.0	1	L14-20P	790
<b>R-SF22-LT</b>	One Door	26.50"	35.38"	83.00"	115	9.6	1694 BTUs	NO	328
<b>R-SF48-LT</b>	Two Door	52.25"	35.38"	83.00"	115	14.0	2400 BTUs	NO	516
<b>R-SF75-LT</b>	Three Door	78.00"	35.38"	83.00"	115/208-230	8.6	2900 BTUs	NO	720

• Specification subject to change without notice

A Division of HMC Enterprises LLC • 831 East Cayuga St • Philadelphia, PA 19124 USA

(215) 464-6800 • 1-800-344-8222 • Fax (215) 969-4890 • E-Mail: sales@howardmccray.com • www.howardmccray.com



## Standard Specification and Optional Features

### CONSTRUCTION

- UL Classified to ANSI/NSF 7
- Top mounted condensing unit
- 5" heavy duty casters
- Foamed in place CFC free foam
- Externally mounted digital display
- Heavy duty edge mount hinges
- Self closing doors

### INTERIOR

- 3 epoxy coated shelves per door
- Aluminum interior

### EXTERIOR

- Stainless front and doors
- Aluminum end panels
- Heavy duty door locks
- Horizontal mounted handle
- Frame heater minimizes moisture around door

### REFRIGERATORS

- R134a
- Capillary tube system
- Electronic control regulates even temperature
- Automatic air defrost
- 115V
- Cord and plug included
- UL/CUL listed

### FREEZER

- R404A Condensing unit
- Capillary tube system
- Electronically controlled with audio alarm
- Automatic air defrost
- Electric evaporator pan - (115V separate plug)
- 115V
- 3 Door units 115V/208-230
- Cord and plug included
- UL/CUL listed

### LIGHTING

- Automatic interior light activates when door is opened

### OPTIONS

- Stainless steel outside ends
- Stainless steel interior
- Laminated door, grill, sides
- Door swing change
- 6" legs top mount units only
- Pan slides
- Extra shelf
- Half-door or glass doors
- Cantilever shelves

## Technical Data

Model No.	SR22-SF22 R-SR22-SF22	SR48-SF48 R-SR48-SF48	SR75-SF75 R-SR75-SF75
<b>Length</b>	26.5"	52.25"	78"
<b>Height with casters</b>	83"	83"	83"
<b>Depth w/drain line &amp; handle</b>	35.38"	35.38"	35.38"
<b>Cubic capacity</b> <small>(Dimensions are +/- 1/4")</small>	22	48	75
<b>Door size</b>	21.125" x 62.25" (1)	21.125" x 62.25" (2)	21.125" x 62.25" (3)
<b>Shelf size</b>	20.75" x 26.188" (3)	23" x 26.188" (3)	25.25" x 26.188" (3) 23" x 26.188" (6)
<b>Shipping Info</b>			
<b>Height</b>	82"	82"	82"
<b>Depth</b>	44"	44"	44"
<b>Length</b>	31"	58"	84"
<b>Gross weight Refrigerators SC/R</b>	328/228	516/401	720/595
<b>Gross weight Freezers SC/R</b>	373/243	550/400	790/615
<b>Cubic feet</b>	73	118	171



### Technical Data

Model No. <b>REFRIGERATORS</b>	SC R	SR22 R-SR22	SR48 R-SR48	SR75 R-SR75
Operating temperature		36°F to 40°F	36°F to 40°F	36°F to 40°F
Refrigerant	SC	R134a	R134a	R134a
Expansion Valve	R	404A	404A	404A
Compressor size HP	SC	1/4	1/3	1/2
Refrigeration system		Electronic controlled	Electronic controlled	Electronic controlled
Air defrost		Self defrost	Self defrost	Self defrost
BTU's at +20°F Evap. Temp.	R	1000	1900	2300
Voltage	SC	115	115	115
Voltage	R	115	115	115
Amperage	SC	6.8	9.6	12.1
Amperage, lights, fans	R	1.1	2.0	2.3
Cord and plug	SC	5-15P	5-15P	5-20P
<b>Model No. FREEZERS- FROZEN FOODS</b>	<b>SC R</b>	<b>SF22 R-SF22</b>	<b>SF48 R-SF48</b>	<b>SF75 R-SF75</b>
Operating temperature		-5°F to 5°F	-5°F to 5°F	-5°F to 5°F
Refrigerant	SC	R404A	R404A	R404A
Expansion Valve	R	R404A	R404A	R404A
Compressor size HP	SC	1/2	1/2	3/4
Refrigeration system		Electronic controlled	Electronic controlled	Electronic controlled
Defrost per day (24hrs)	Electric	3 per day	3 per day	3 per day
BTU's at -15°F Evap. Temp.	R	1556	2100	3400
Voltage	SC	115	115	115/208-230
Voltage, lights, fans, defrost heaters	R	115	115	115
Amperage	SC	12.0	16.0	12.0
Voltage, lights, fans, defrost heaters	R	9.6	14.0	8.6
Cord and plug	SC R	5-15P NO	5-20P NO	L14-20P NO
<b>Model No. FREEZERS- LOW TEMP</b>	<b>SC R</b>	<b>SF22-IC R-SF22-IC</b>	<b>SF48-IC R-SF48-IC</b>	<b>SF75-IC R-SF75-IC</b>
Operating temperature		-5°F+ to -5°F	-5°F+ to -5°F	-5°F+ to -5°F
Refrigerant	SC	R404A	R404A	R404A
Expansion Valve	R	R404A	R404A	R404A
Compressor size HP	SC	1/2	3/4	1
Refrigeration system		Electronic controlled	Electronic controlled	Electronic controlled
Defrost per day (24hrs)	Electric	3 per day	3 per day	3 per day
BTU's at -25°F Evap. Temp.	R	1694	2400	2900
Voltage	SC	115	115	115/208-230
Voltage, lights, fans, defrost heaters	R	115	115	115
Amperage	SC	12.0	16.0	13.0
Voltage, lights, fans, defrost heaters	R	9.6	14.0	8.6
Cord and plug	SC R	5-15P NO	5-20P NO	L14-20P NO

Specification subject to change without notice



**Technical Data • Side View • Plan View**

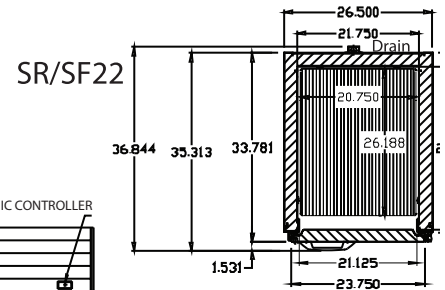
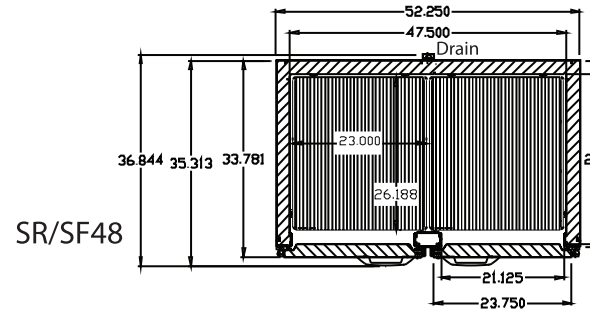
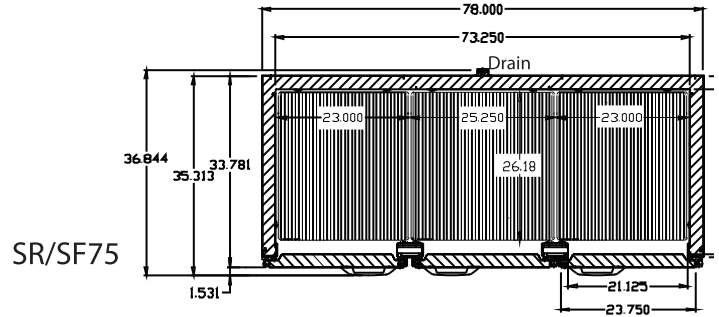
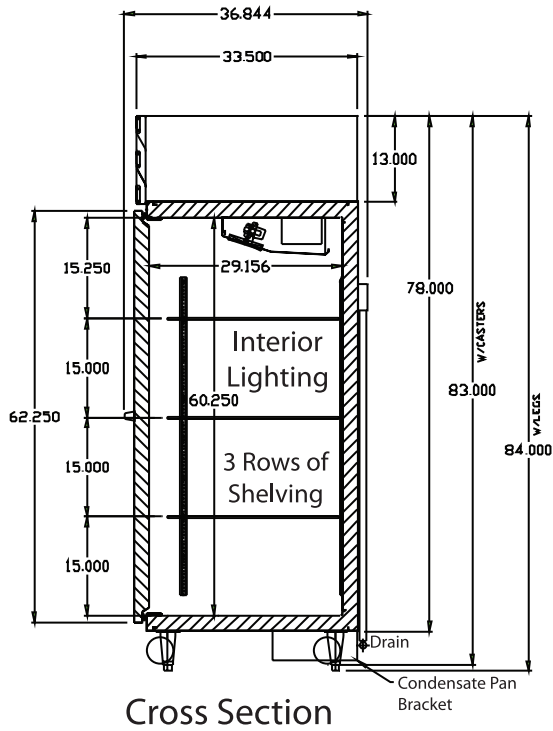

**Plan View:**

