

VICTORY[®]

ULTRASPEC

PROJECT: _____

ITEM # _____ QTY: _____

MODEL # _____

AIA # _____ SIS # _____

EXTRA WIDE DUAL TEMP REACH-IN WARMING CABINET & REFRIGERATOR

HRS-2D-S1-EW-HC



CABINET CONSTRUCTION

- Stainless Steel Exterior And Interior
- Stainless Steel Interior Door Liner
- Warming Cabinet On Top, Refrigerator On Bottom
- Stay-Open Door Feature For Easy Product Loading
- 20 Gauge Stainless Steel Door
- Left: Warmer, Right Refrigerator
- Refrigerator Has Magnetic Door Switch Automatically Activates Interior LED Light
- Warmer Has Magnetic Door Switch Automatically Activates Interior Incandescent Light
- Heavy-Duty Cylinder Locks
- One-Piece, Snap-In Magnetic Door Gaskets
- Low Profile Vertical Door Handles
- Hinged Front Shroud
- Thermal Breaker
- Stainless Steel Breaker Caps
- Six Silver Freeze Wire Shelves
- 6" High Adjustable Stainless Steel Legs
- 8' Cord And Plug (see electrical data for details)

FEATURES

- Full Electronic Control With Touchpoint Interface
- Expansion Valve Technology (refrigerator only)
- Insulated Partition Wall Separates Compartments

REFRIGERATION

- Refrigeration System Uses R290 Refrigerant To Comply With All Environmental Concerns
- Hot Gas Condensate Evaporator
- Automatic Non-Electric, Defrost
- Epoxy Coated Evaporator Coil, Located Out Of The Food Zone
- Refrigerator Capable Of Maintaining Product Temperature 36°F to 38°F

HEATING

- Warming Cabinet Maintains Product Temperature 80°F to 180°F



- ▶ 3 Year Parts & Labor Warranty Plus An Additional 4 Year Compressor Warranty
- ▶ Exclusive 2 Year Warranty On Magnetic Door Gaskets
- ▶ Lifetime Warranty On Handles & Hinges (Parts Only)



Please verify qualifying units by visiting:
www.energystar.gov/cfs

OPTIONS & ACCESSORIES

- | | | |
|------------------------------|---|---|
| • Secure-Temp™ Technology | • Exterior Door Laminate | • 6" Casters 6" Seismic Legs |
| • Stainless Steel Case Back | • Additional Shelves | • Correctional Package |
| • Stainless Steel Kick Plate | • Tray Slides (type A & A/C) | • Remote Models* (refrigerators & 6" legs only)
(refrigerant must be specified at time of order, see note on back on page) |
| • Glass Door Models | • Door Swing Orientation (at time of order) | |

3779 Champion Blvd, Winston-Salem, NC 27105

ph: (888) 845-9800 | fax: (800) 253-5168

Sales@VictoryRefrigeration.com | VictoryRefrigeration.com

Rev. 8/20/20 Printed in the U.S.A.

APPROVAL: _____ DATE: _____

EXTRA WIDE DUAL TEMP REACH-IN WARMING CABINET & REFRIGERATOR

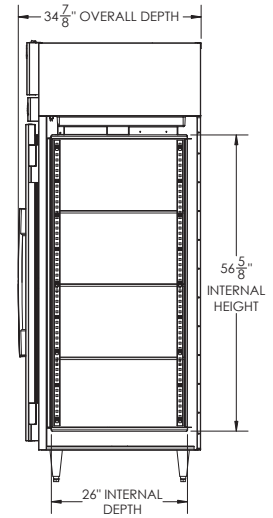
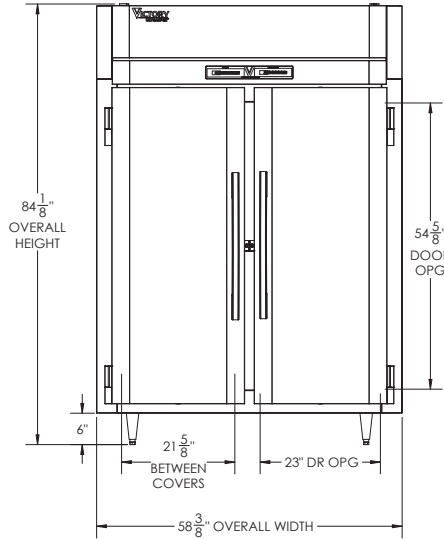
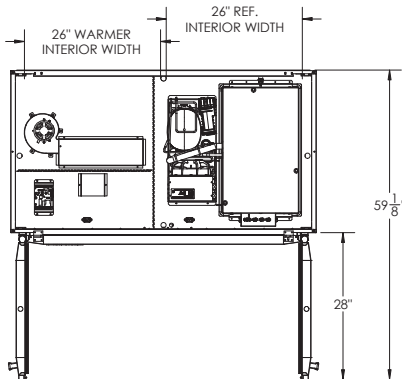

We reserve the right to change specifications and product design without notice. Such revisions do not entitle the buyer to corresponding changes, improvements, additions or replacements for previously purchased equipment. Dimensional tolerances +/- 1/4". Metric dimensions (MM)

12" top, 3" sides and rear clearance is required

CHARACTERISTICS		ELECTRICAL DATA REFRIGERATOR		SHIPPING DETAILS	
Net Capacity R/W	23.8 / 23.8	Cabinet Voltage	115/60/1	Height	88"
Width, Overall (in.)	58 3/8"	Total Amperes	6.5	Width	66"
Depth, Overall (with Handle)	34 7/8"	NEMA Plug* (8' cord)	5-15P	Depth	41"
Height Overall (6" legs)	84 1/8"	REFRIGERATION DATA		Crated Weight	625 lbs
Depth, Door Open 90°	59 1/8"	Condensing Unit Size, HP*	1/3	*NOTE: Remote units are field wired and come with 6" legs. Refrigerant must be specified at time of order.	
Door Opening (in.)	23" x 54 5/8"	Refrigerant*	R290		
No. Of Doors / Shelves	2/6	Capacity (BTU/HR) (100°F/20°F)	Variable Speed Technology		
		ELECTRICAL DATA WARMING CABINET			
		Cabinet Voltage	230/60/1		
		Total Amperes	3.2/3.7		
		NEMA Plug* (8' cord)	6-20P		

3779 Champion Blvd, Winston-Salem, NC 27105 | ph: (888) 845-9800 | fax: (800) 253-5168

Sales@VictoryRefrigeration.com | VictoryRefrigeration.com

Rev. 8/20/20 Printed in the U.S.A.

an Ali Group Company



The Spirit of Excellence