

Food Rethermalizer/Bain-Marie Heater

Model JFR

Works with a food rethermalizer or bain-marie to provide continuous hot water that heats & holds foods at safe-serving temperatures.



Applications:

- Food Rethermalizer
- Bain-Marie

Model JFR

The Hubbell model JFR is designed to heat or hold food at safe serving temperatures when used with a food rethermalizer or bain-marie. Mounted under a sink or holding vessel and typically set between 140°F and 190°F, the Hubbell model JFR provides continuously circulated hot water to efficiently satisfy safe serving requirements and prevent cold spots.

Features and Benefits

- The all stainless steel body and base comes standard on every model
- Electronic controls provide precise and consistent water temperatures
- Digital display for visual confirmation of set point temperature and fault conditions
- Equipped with an energy cut-off (ECO) for built-in protection against higher than normal water temperatures
- Low water cut off to prevent element burnout
- ETL & ETL Sanitation (ANSI-NSF4) listed
- Shipped ready to install with all gaskets and fittings
- Straight thread, screw-type elements with o-ring gasket for easy replacement
- Separate sump and heating compartment drains allow for easy cleaning and sanitizing
- Standard 2" plumbing fittings for mounting into a holding vessel
- Multiple voltage options available



Dimensions

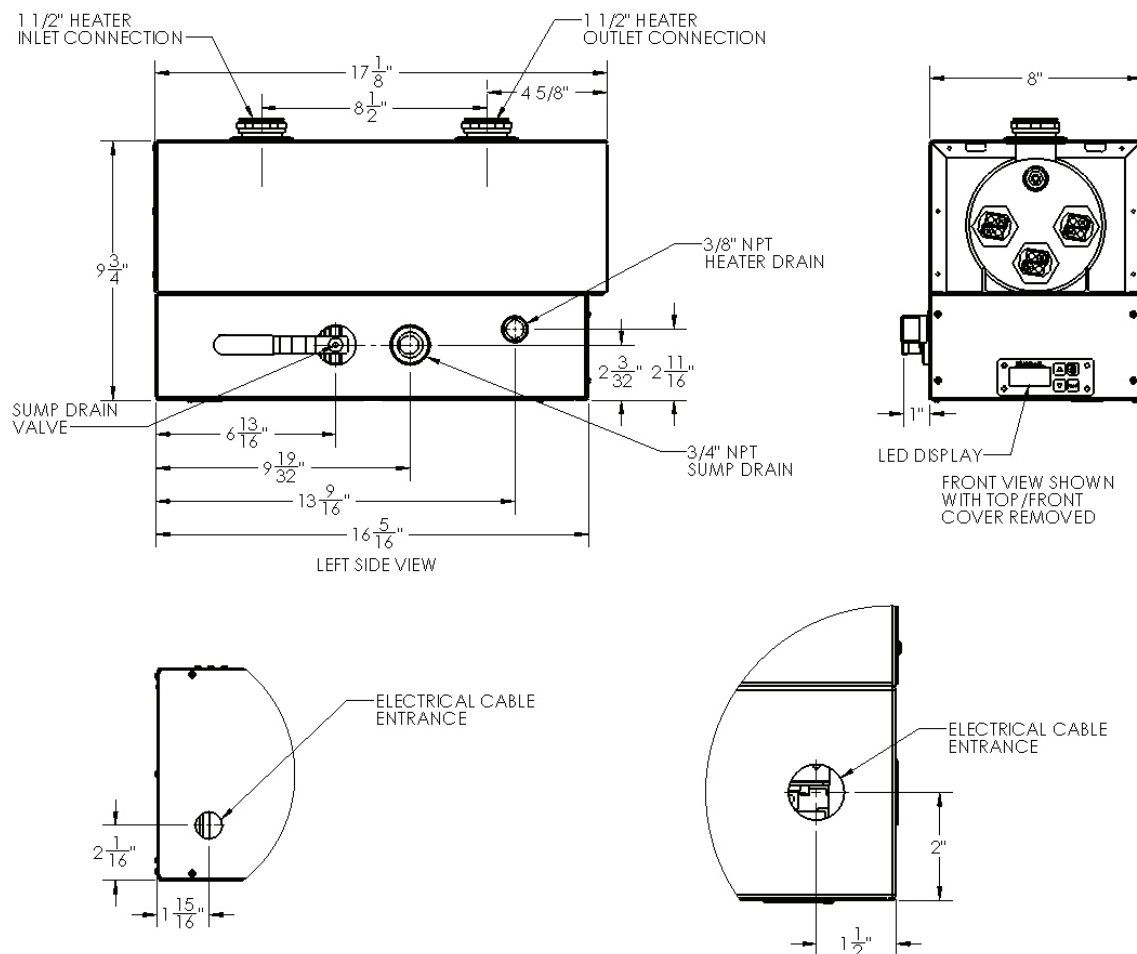

Model JFR

Sizing Information

For a Food Rethermalizer:

Minimum of 2000 watts per square foot (2.2 watts per square cm) of vessel top.

For a Bain-Marie or Steam Table:

Minimum of 750 watts per square foot (0.8 watts per square cm) of vessel top. Units over 6' long require a minimum of two JFR heaters.

Water Quality Requirements:

Incoming water in excess of 3.0 grains of hardness per gallon (GPG) (.75 grains of hardness per liter) must be treated and softened before being supplied to hot water dispenser(s). Water containing over 3.0 GPG (.75 GPL) will decrease efficiency and reduce the longevity of the heater.

Note: Product failure caused by liming or sediment buildup is not covered under warranty.

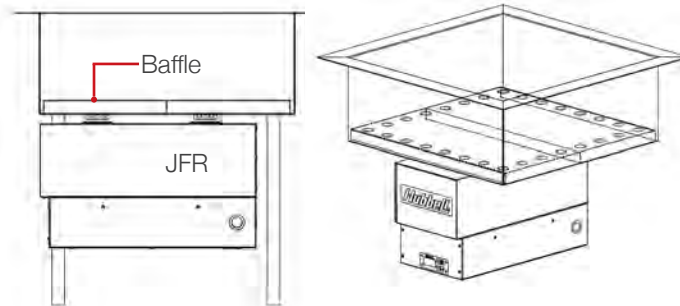

Baffle Information:

The JFR must be installed with a perforated water baffle. This baffle is not supplied with the heater.

The JFR should be positioned with no more than 3' (91.4 cm) on either side when mounted in the holding vessel.

Model Number Configurator

JFR -

Step 1

kW

3
4
6
9

Step 2

Voltage/Phase:

1 Φ Voltages	3 Φ Voltages
RS = 208 -1	R = 208 - 3
S = 240 -1	T = 240 - 3
W = 277 -1	T3 = 380 - 3
T4S = 480 -1	T7 = 415 - 3
	T4 = 480 - 3
	T6 = 600 - 3

Example:

JFR - 3R
3 kW, 208 - 3

Options:

Security Package (Includes Torx[®] screws and digital display cover)

Warranty:

All Hubbell Model JFR booster heaters are backed by a full 1 year parts/labor warranty and additional 4 year tank warranty.

Notes:

- All three phase JFR models are designed with balanced loads.
- The Hubbell JFR is suitable for cold or pre-heated water use.

Food Rethermalizing Requirements

NSF Standard 4 requires, for products manufactured for the purpose of rethermalizing food, that the food reach a safe serving temperature of 165°F in two hours or less in order to be listed to the NSF4 standard. The Hubbell model JFR is designed specifically for food rethermalizing, but only in conjunction with a hot water bath rethermalizer. Hubbell supplies neither the vessel nor the system that determines how food is placed and held in the vessel. The Hubbell JFR only supplies hot water to the vessel. Each vessel must pass its own NSF performance requirements and although Hubbell provides sizing recommendations to help correctly size the JFR to the vessel, there are many variables involved in the manufacturing of the vessel that impact its ability to pass the NSF requirements. The Hubbell JFR is ETL and ETL Sanitation (ANSI NSF 4) listed for construction only. It is the responsibility of the manufacturer of the vessel to have the complete rethermalizing product tested and listed to the NSF 4 Standard once the JFR is installed onto the vessel.



Hubbell provides a complete line of commercial foodservice water heaters to meet your specific application needs.



Quick, Easy and Accurate

With only a few clicks, you will be able to send quotes/specifications directly to dealers and consultants quickly and efficiently.

www.hubbellheaters.com

Hubbell Heaters | 45 Seymour Street | P.O. Box 288 | Stratford, CT 06615

P: 203.378.2659 | F: 203.378.3593

