



**John
BOOS**
Since 1887

ITEM #: _____ QTY: _____
 MODEL #: _____
 PROJECT NAME: _____

3601 S. Banker St. Effingham, IL 62401 • P.O. BOX 609 • Ph: (888) 431-2667 • Fax: (800) 433-2667

"E1S8" - 1 COMPARTMENT "E-SERIES" SINKS WITH GALVANIZED LEGS



FEATURES:

- 18GA STAINLESS STEEL
- TYPE 300 STAINLESS STEEL WITH #4 POLISH, SATIN FINISH
- 12" AND 14" DEEP BOWLS
- ALL CORNERS, BOTH VERTICAL AND HORIZONTAL, COVED AT 3/4" RADIUS
- BOTTOMS OF BOWLS FORMED FOR DRAINAGE TO 3-1/2" DIAMETER DIE STAMPED OPENING
- FULL LENGTH **10" HIGH BOXED BACKSPLASH**, WITH 2" RETURN TO WALL AT 45 DEGREE AND 1" TILE EDGE
- 1" FAUCET HOLES IN BACKSPLASH
- ALL OUTSIDE CORNERS OF ASSEMBLY ARE BULLNOSED TO PROVIDE SAFE, CLEAN, AND POLISHED EDGE
- STANDARD STAINLESS STEEL LEGS 1-5/8" DIAMETER
- LEGS LOCATED DIRECTLY UNDER SINK BOWLS, PROVIDING INCREASEDE STABILITY AND MAX WEIGHT SUPPORT

CONSTRUCTION:

- TOP: STAINLESS STEEL SINKS ARE TIG WELDED, EXPOSED WELDS ARE POLISHED TO MATCH ADJACENT SURFACE
- BASE: GALVANIZED STEEL

MATERIAL:

- BOWLS & TOP: 18GA TYPE 300 STAINLESS STEEL WITH #4 POLISH, SATIN FINISH
- LEGS: 1-5/8" ROUND O.D. GALVANIZED STEEL
- GUSSETS: GALVANIZED STEEL
- FEET: 1" PLASTIC BULLET FEET

12" DEEP - 1 COMP SINK - 18GA

MODEL	BOWL SIZE (LxWxD)	QTY
E1S8-1620-12	16" X 20" X 12"	
E1S8-18-12	18" X 18" X 12"	

14" DEEP - 1 COMP SINK - 18GA

MODEL	BOWL SIZE (LxWxD)	QTY
E1S8-1824-14	18" X 24" X 14"	
E1S8-24-14	24" X 24" X 12"	



E1S8-1824-14

"E1S8" - 1 COMPARTMENT "E SERIES" SINKS DETAILED SPECIFICATIONS

12" DEEP - SINK DIMENSIONS

A	B	C	D
14-1/4"	12"	10"	43-3/4"

14" DEEP - SINK DIMENSIONS

A	B	C	D
16-1/4"	14"	10"	43-3/4"

BOWL DIMENSIONS

LENGTH x WIDTH	F	G	H
16" X 20"	25-1/2"	20"	12-15/16"
18" X 18"	23-1/2"	18"	11-15/16"
18" X 24"	29-1/2"	24"	14-15/16"
24" X 24"	29-1/2"	24"	14-15/16"

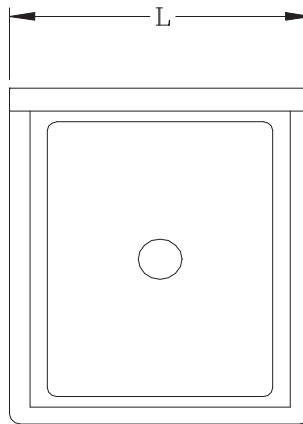
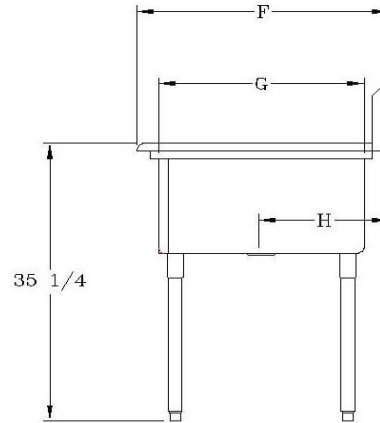
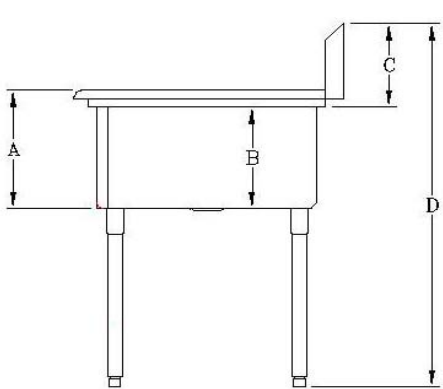

12" DEEP - 1 COMP SINK - 18GA

MODEL	BOWL SIZE (LxWxD)	DIMENSIONS	DRAIN BOARDS	WT. (LBS)
E1S8-1620-12	16" X 20" X 12"	21" X 25-1/2"	-	50
E1S8-18-12	18" X 18" X 12"	23" X 23-1/2"	-	50

14" DEEP - 1 COMP SINK - 18GA

MODEL	BOWL SIZE (LxWxD)	DIMENSIONS	DRAIN BOARDS	WT. (LBS)
E1S8-1824-14	18" X 24" X 14"	23" X 29-1/2"	-	68
E1S8-24-14	24" X 24" X 24"	29" X 29-1/2"	-	74

SOME UNITS SHIP UNASSEMBLED FOR REDUCED SHIPPING COST. ALL DIMENSIONS ARE TYPICAL. TOLERANCE +/- .500"
John Boos & Co. is constantly engaged in a program of improving products and therefore reserves the right to change specifications without prior notice.



3601 S. Banker St. • Effingham, IL 62401 • PO BOX 609 • quotes@johnboos.com

Boos
lock

AQ AutoQuotes

www.johnboos.com