



**John
BOOS**
Since 1887

ITEM #: _____ QTY: _____

MODEL #: _____

PROJECT NAME: _____

3601 S. Banker St. Effingham, IL 62401 • P.O. BOX 609 • Ph: (888) 431-2667 • Fax: (800) 433-2667

"EPT6R5" STAINLESS STEEL PREP TABLE W/ SINK



16GA STAINLESS STEEL WORK TOP WITH GALVANIZED BASE AND ADJUSTABLE UNDERSHELF

FEATURES:

- 16 GAUGE STAINLESS STEEL TOP W/ 5" RISER & TURNDOWN
- TYPE 300 STAINLESS STEEL WITH # 4 POLISH, SATIN FINISH
- 1 1/2" STALLION EDGE ON FRONT WITH SIDE EDGES 90 DEGREE BEND DOWN FOR TABLE LINE-UP
- (1) 16" X 20" X 12" BOWL
- GALVANIZED STEEL BASE WITH ADJUSTABLE UNDERSHELF
- ADJUSTABLE BULLET FEET
- SHIPPED KNOCKED-DOWN, EASY-TO-ASSEMBLE
- NSF CERTIFIED
- INCLUDES (1) DECK MOUNTED FAUCET 4" O/C W/ 10" SWING SPOUT



CONSTRUCTION:

- TOP: STAINLESS STEEL TOPS ARE TIG WELDED, EXPOSED WELDS ARE POLISHED TO MATCH ADJACENT SURFACE.

MATERIAL:

- TOP: 16 GAUGE STAINLESS STEEL TYPE 300 STAINLESS STEEL WITH # 4 POLISH, SATIN FINISH
- SHELF: 18 GAUGE GALVANIZED STEEL,
- LEGS: 1 5/8" ROUND O.D. 16 GAUGE TUBULAR GALVANIZED STEEL
- GUSSETS: GALVANIZED STEEL
- FEET: 1" ADJUSTABLE GALVANIZED BULLET FEET



PBF-4DM-10LF

30" WIDE	QTY
EPT6R5-3060GSK-L	
EPT6R5-3060GSK-R	
EPT6R5-3072GSK-L	
EPT6R5-3072GSK-R	



ADJUSTABLE UNDERSHELF

DETAILED SPECIFICATIONS

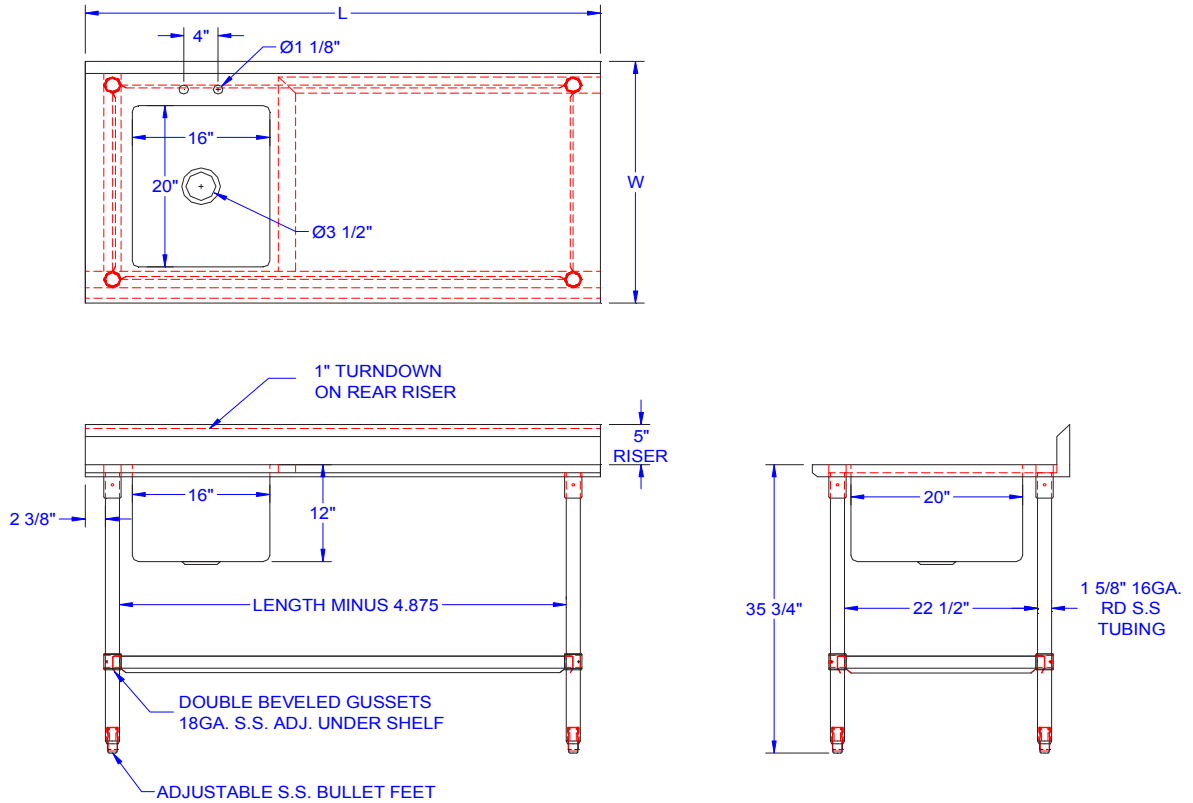

- UNITS 7 FT. AND LARGER ARE FURNISHED WITH SIX LEGS.
- FINISHED SIZE OF UNDERSHELF.
SHELF LENGTH = LENGTH MINUS 4.875"
SHELF WIDTH = WIDTH MINUS 4.25"

16 GAUGE TOP W/ ADJUSTABLE UNDERSHELF

LENGTH	30" WIDE	WT. (LBS)
60"	EPT6R5-3060GSK-L	171
60"	EPT6R5-3060GSK-R	171
72"	EPT6R5-3072GSK-L	202
72"	EPT6R5-3072GSK-R	202

MODEL # STRUCTURE

30 = WIDTH OF WORK SURFACE
 5 = HT. OF RISER W/ TURNDOWN
 R = RISER TOP WORK TABLE
 6 = 16GA WORK SURFACE
 EPT=ECONOMY PREP TABLE
 60 = LENGTH OF WORK SURFACE
 GS = GALVANIZED LEGS & SHELF
 K = K.D. W/ ADJUSTABLE SHELF
 L = BOWL LOCATION

EPT6R5-3060GSK-L

SOME UNITS SHIP UNASSEMBLED FOR REDUCED SHIPPING COST. ALL DIMENSIONS ARE TYPICAL. TOLERANCE +/- .500"
 John Boos & Co. is constantly engaged in a program of improving products and therefore reserves the right to change specifications without prior notice.



3601 S. Banker St. • Effingham, IL 62401 • PO BOX 609 • quotes@johnboos.com

Boos
lock

AQ AutoQuotes

www.johnboos.com