



**John
BOOS**
Since 1887

ITEM #: _____ QTY: _____
 MODEL #: _____
 PROJECT NAME: _____

3601 S. Banker St. Effingham, IL 62401 • P.O. BOX 609 • Ph: (888) 431-2667 • Fax: (800) 433-2667

"FBLG" STAINLESS STEEL TOP WORK TABLES



18GA TOP AND GALV LEGS AND ADJUSTABLE UNDERSHELF

BUDGET E-SERIES

FEATURES:

- 18 GAUGE STAINLESS STEEL TOP
- TYPE 430 STAINLESS STEEL WITH SATIN FINISH
- TOP IS SOUND DEADENED
- REINFORCED WITH 1"X2" CHANNEL RUNNING ENTIRE LENGTH OF TABLE
- 1-1/2" STALLION EDGE ON FRONT AND REAR WITH SIDE EDGES 90 DEGREE BEND DOWN FOR TABLE LINE-UP
- GALVANIZED BASE AND ADJUSTABLE UNDERSHELF
- ADJUSTABLE BULLET FEET
- SHIPPED KNOCKED-DOWN, EASY-TO-ASSEMBLE
- NSF AND CSA CERTIFIED



FBLG4830

CONSTRUCTION:

- TOP: STAINLESS STEEL TOPS ARE TIG WELDED, EXPOSED WELDS ARE POLISHED TO MATCH ADJACENT SURFACE.

MATERIAL:

- TOP: 18 GAUGE STAINLESS STEEL TYPE 430 STAINLESS STEEL WITH SATIN FINISH
- SHELF: 18 GAUGE GALVANIZED STEEL
- LEGS: 1-5/8" ROUND O.D. 16 GAUGE TUBULAR GALVANIZE STEEL
- GUSSETS: GALVANIZED STEEL
- FEET: 1" ADJUSTABLE PLASTIC BULLET FEET



ADJUSTABLE SHELF

18 GAUGE TOP W/ ADJUSTABLE UNDERSHELF

24" WIDE	QTY	30" WIDE	QTY
FBLG2424		-	
FBLG3024		FBLG3030	
FBLG3624		FBLG3630	
FBLG4824		FBLG4830	
FBLG6024		FBLG6030	
FBLG7224		FBLG7230	
FBLG8424		FBLG8430	
FBLG9624		FBLG9630	

OPTIONAL ACCESSORIES

DESCRIPTION	MODEL #	QTY
REAR 1-1/2" BACKSPLASH		

DETAILED SPECIFICATIONS

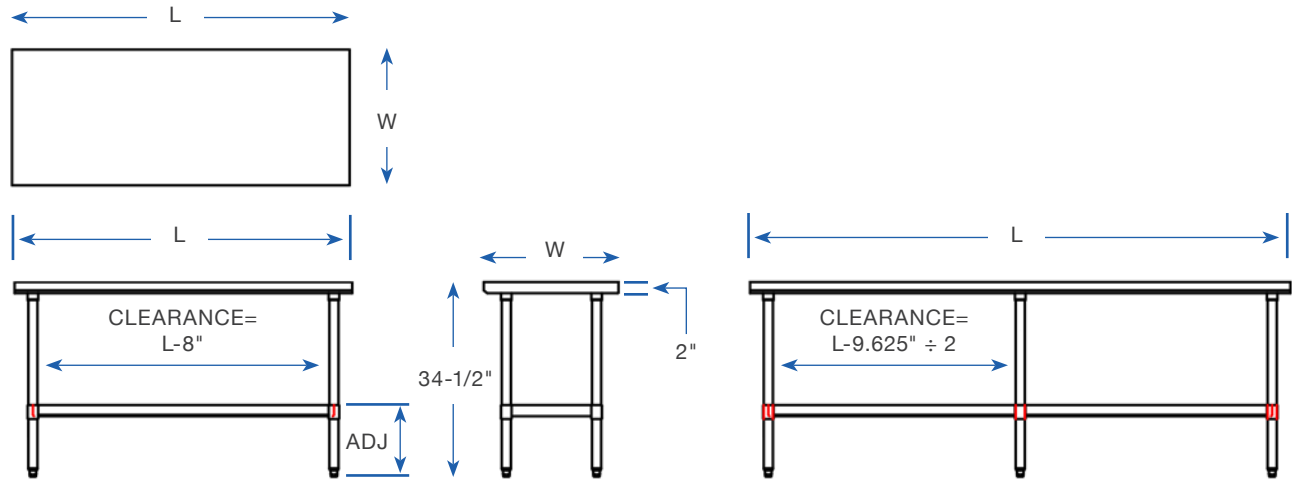

- UNITS 7 FT. AND LARGER ARE FURNISHED WITH SIX LEGS.
- FINISHED SIZE OF UNDERSHELF.
 SHELF LENGTH = LENGTH MINUS 4.875"
 SHELF WIDTH = WIDTH MINUS 4.25"

18 GAUGE TOP W/ ADJUSTABLE UNDERSHELF

LENGTH	24" WIDE	WT. (LBS)	30" WIDE	WT. (LBS)
24"	FBLG2424	44	-	-
30"	FBLG3024	48	FBLG3030	50
36"	FBLG3624	50	FBLG3630	56
48"	FBLG4824	64	FBLG4830	69
60"	FBLG6024	71	FBLG6030	82
72"	FBLG7224	83	FBLG7230	94
84"	FBLG8424	103	FBLG8424	116
96"	FBLG9624	114	FBLG9624	128

SOME UNITS SHIP UNASSEMBLED FOR REDUCED SHIPPING COST. ALL DIMENSIONS ARE TYPICAL. TOLERANCE +/- .500"
 John Boos & Co. is constantly engaged in a program of improving products and therefore reserves the right to change specifications without prior notice.

