



**John  
BOOS**  
Since 1887

ITEM #: \_\_\_\_\_ QTY: \_\_\_\_\_  
 MODEL #: \_\_\_\_\_  
 PROJECT NAME: \_\_\_\_\_

3601 S. Banker St. Effingham, IL 62401 • P.O. BOX 609 • Ph: (888) 431-2667 • Fax: (800) 433-2667

## "GS" GRIDDLE STANDS W/ GALV BASE



### FEATURES:

- 16GA STAINLESS STEEL
- TYPE 300 STAINLESS STEEL WITH #4 POLISH, SATIN FINISH
- 1-1/2" TURNED UP BACK AND BOTH ENDS, W/ 7/8" RADIUS FRONT EDGE
- TOP IS REINFORCED BY A FULL FRAME, FABRICATED OF 1-1/2" SQUARE O.D. TUBE 16GA PRE-GALVANIZED STEEL.
- MAPLE BUTCHER BLOCK CUTTING BOARD ON ADJUSTABLE STAINLESS STEEL BRACKETS
- GALVANIZED BASE AND BRACING AND/OR SHELF FABRICATED OF 100% PRE-GALVANIZED STEEL - **NOT PLATED**
- BRACING ADJUSTABLE TO DESIRED HEIGHT
- SHIPPED KNOCKED-DOWN, EASY-TO-ASSEMBLE

### CONSTRUCTION:

- TOP: STAINLESS STEEL TOPS ARE TIG WELDED, EXPOSED WELDS ARE POLISHED TO MATCH ADJACENT SURFACE
- BASE: MIG WELDED GALVANIZED FRAME

### MATERIAL:

- TOP: 16GA TYPE 300 STAINLESS STEEL WITH #4 POLISH, SATIN FINISH
- BRACING: 1-1/4" ROUND O.D. TUBULAR GALVANIZED STEEL  
100% PRE-GALVANIZED - **NOT PLATED**
- SHELF: 18GA GALVANIZED STEEL  
100% PRE-GALVANIZED - **NOT PLATED**
- LEGS: 1 5/8" ROUND O.D. 16GA TUBULAR GALVANIZED STEEL  
100% PRE-GALVANIZED - **NOT PLATED**
- GUSSETS: GALVANIZED STEEL

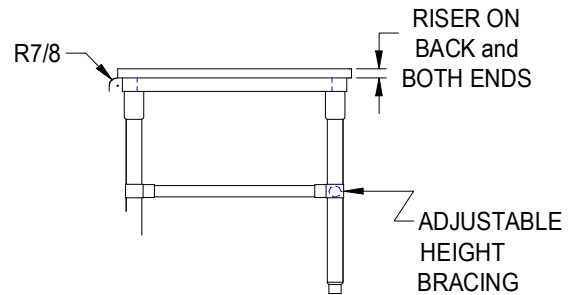
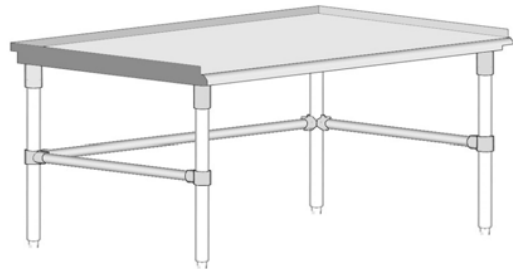

### 16GA GRIDDLE STAND W/O LOWER SHELF

24"	QTY	30"	QTY	36"	QTY
GS01		GS05		-	
GS02		GS06		GS09	
GS03		GS07		GS10	
GS04		GS08		GS11	

### 16GA GRIDDLE STAND W/ GALV LOWER SHELF

24"	QTY	30"	QTY	36"	QTY
GS20		GS24		-	
GS21		GS25		GS28	
GS22		GS26		GS29	
GS23		GS27		GS30	

### OPTIONAL ACCESSORIES

DESCRIPTION	MODEL #	QTY
MAPLE CUTTING BOARDS		
STAINLESS STEEL BASE		
STAINLESS STEEL FEET		
WELDED SET - UP		

# GRIDDLE STANDS DETAILED SPECIFICATIONS

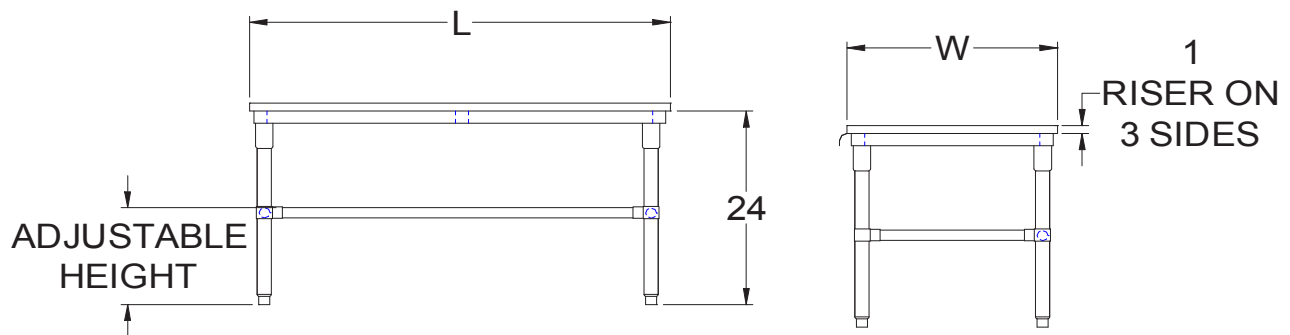
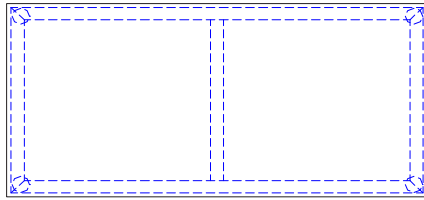

## 16GA GRIDDLE STAND W/O LOWER BRACE

LENGTH	24" WIDE	WT. (LBS)	30" WIDE	WT. (LBS)	36" WIDE	WT. (LBS)
36"	GS01	65	GS05	69	-	-
48"	GS02	80	GS06	90	GS09	100
60"	GS03	95	GS07	111	GS10	127
72"	GS04	111	GS08	132	GS11	154

## 16GA GRIDDLE STAND W/GALV LOWER SHELF

LENGTH	24" WIDE	WT. (LBS)	30" WIDE	WT.	36" WIDE	WT. (LBS)
36"	GS20	75	GS24	75	-	-
48"	GS21	90	GS25	100	GS28	110
60"	GS22	115	GS26	131	GS29	147
72"	GS23	141	GS27	162	GS30	184

SOME UNITS SHIP UNASSEMBLED FOR REDUCED SHIPPING COST. ALL DIMENSIONS ARE TYPICAL. TOLERANCE +/- .500"  
John Boos & Co. is constantly engaged in a program of improving products and therefore reserves the right to change specifications without prior notice.