



**John
BOOS**
Since 1887

ITEM #: _____ QTY: _____
 MODEL #: _____
 PROJECT NAME: _____

3601 S. Banker St. Effingham, IL 62401 • P.O. BOX 609 • Ph: (888) 431-2667 • Fax: (800) 433-2667

"ST4-GSK" STAINLESS STEEL TOP WORK TABLES

14GA TOP AND GALV LEGS AND ADJUSTABLE UNDERSHELF



FEATURES:

- 14 GAUGE STAINLESS STEEL TOP
- TYPE 300 STAINLESS STEEL WITH # 4 POLISH, SATIN FINISH
- TOP IS SOUND DEADENED
- REINFORCED WITH 1"X2" CHANNEL RUNNING ENTIRE LENGTH OF TABLE
- 1-1/2" STALLION EDGE ON FRONT AND REAR WITH SIDE EDGES
90 DEGREE BEND DOWN FOR TABLE LINE-UP
- GALVANIZED BASE WITH ADJUSTABLE UNDERSHELF
- SHIPPED KNOCKED-DOWN, EASY-TO-ASSEMBLE
- NSF AND CSA CERTIFIED



ST4-3048GSK

CONSTRUCTION:

- TOP: STAINLESS STEEL TOPS ARE TIG WELDED,
EXPOSED WELDS ARE POLISHED TO MATCH ADJACENT SURFACE.

MATERIAL:

- TOP: 14 GAUGE STAINLESS STEEL TYPE 300 STAINLESS STEEL WITH
4 POLISH, SATIN FINISH
- SHELF: 18 GAUGE GALVANIZED STEEL
(36" WIDE TABLES, 16 GAUGE LOWER SHELF)
- LEGS: 1-5/8" ROUND O.D., 16 GAUGE TUBULAR GALVANIZED STEEL
- GUSSETS: GALVANIZED STEEL
- FEET: 1" ADJUSTABLE GALVANIZED BULLET FEET



ADJUSTABLE LOWER SHELF

14 GAUGE TOP W/ ADJUSTABLE BRACING

24" WIDE	QTY	30" WIDE	QTY	36" WIDE	QTY
ST4-2436GSK		ST4-3036GSK		ST4-3636GSK	
ST4-2448GSK		ST4-3048GSK		ST4-3648GSK	
ST4-2460GSK		ST4-3060GSK		ST4-3660GSK	
ST4-2472GSK		ST4-3072GSK		ST4-3672GSK	
ST4-2484GSK		ST4-3084GSK		ST4-3684GSK	
ST4-2496GSK		ST4-3096GSK		ST4-3696GSK	
ST4-24108GSK		ST4-30108GSK		ST4-36108GSK	
ST4-24120GSK		ST4-30120GSK		ST4-36120GSK	

OPTIONAL ACCESSORIES

DESCRIPTION	MODEL #	QTY
DRAWER		
DRAWER LOCK		
CASTERS		
OVERSHELVES		
SINKS		
POT RACK		

DETAILED SPECIFICATIONS

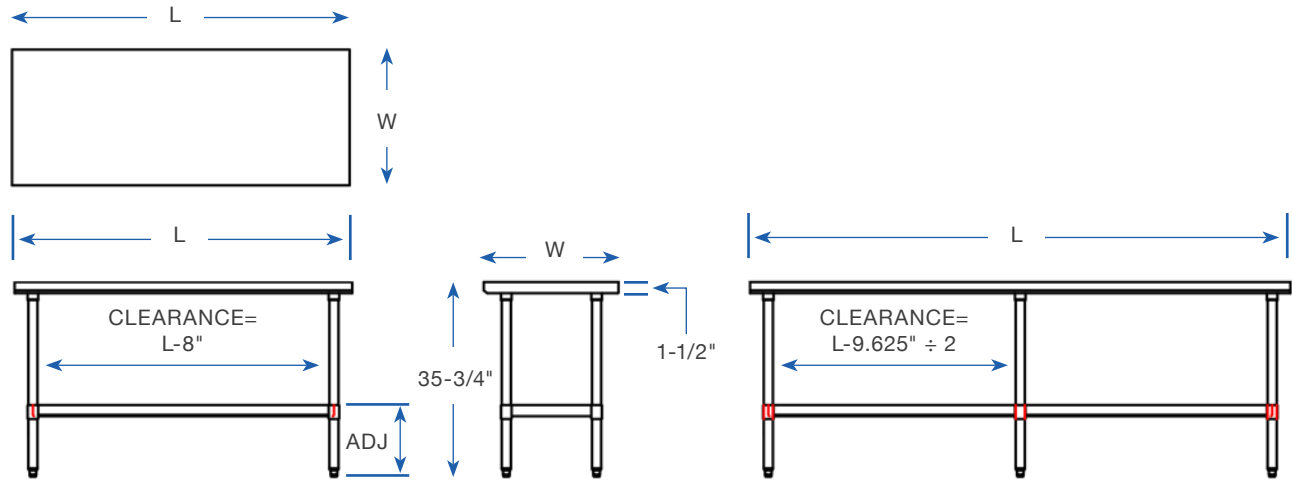

- UNITS 7 FT. AND LARGER ARE FURNISHED WITH SIX LEGS.
- FINISHED SIZE OF UNDERSHELF.
SHELF LENGTH = LENGTH MINUS 4.875"
SHELF WIDTH = WIDTH MINUS 4.25

14 GAUGE TOP W/ ADJUSTABLE UNDERSHELF

LENGTH	24" WIDE	WT. (LBS)	30" WIDE	WT. (LBS)	36" WIDE	WT. (LBS)
36"	ST4-2436GSK	57	ST4-3036GSK	65	ST4-3636GSK	85
48"	ST4-2448GSK	71	ST4-3048GSK	82	ST4-3648GSK	92
60"	ST4-2460GSK	84	ST4-3060GSK	98	ST4-3660GSK	111
72"	ST4-2472GSK	103	ST4-3072GSK	121	ST4-3672GSK	138
84"	ST4-2484GSK	118	ST4-3084GSK	138	ST4-3684GSK	157
96"	ST4-2496GSK	133	ST4-3096GSK	154	ST4-3696GSK	175
108"	ST4-24108GSK	147	ST4-30108GSK	170	ST4-36108GSK	194
120"	ST4-24120GSK	160	ST4-30120GSK	186	ST4-36120GSK	213

MODEL # STRUCTURE

30 = WIDTH OF WORK SURFACE 120 = LENGTH OF WORK SURFACE
 4 = 14GA WORK SURFACE GS = GALVANIZED LEGS & SHELF
 ST = STAINLESS STEEL TOP K = K.D. W/ ADJUSTABLE BRACING

ST4-30120GSK

SOME UNITS SHIP UNASSEMBLED FOR REDUCED SHIPPING COST. ALL DIMENSIONS ARE TYPICAL. TOLERANCE +/- .500"
 John Boos & Co. is constantly engaged in a program of improving products and therefore reserves the right to change specifications without prior notice.



3601 S. Banker St. • Effingham, IL 62401 • PO BOX 609 • quotes@johnboos.com



www.johnboos.com