



**John  
BOOS**  
Since 1887

ITEM #: \_\_\_\_\_ QTY: \_\_\_\_\_  
 MODEL #: \_\_\_\_\_  
 PROJECT NAME: \_\_\_\_\_

3601 S. Banker St. Effingham, IL 62401 • P.O. BOX 609 • Ph: (888) 431-2667 • Fax: (800) 433-2667

## **"ST4R5-SSK" STAINLESS STEEL TOP WORK TABLES**

### **14GA TOP W/5" RISER AND STAINLESS STEEL LEGS AND ADJUSTABLE UNDERSHELF**



#### **FEATURES:**

- 14 GAUGE STAINLESS STEEL TOP W/ 5" RISER & TURNDOWN
- TYPE 300 STAINLESS STEEL WITH # 4 POLISH, SATIN FINISH
- TOP IS SOUND DEADENED
- REINFORCED WITH 1"X2" CHANNEL RUNNING ENTIRE LENGTH OF TABLE
- 1-1/2" STALLION EDGE ON FRONT SIDE EDGES
- 90 DEGREE BEND DOWN FOR TABLE LINE-UP
- STAINLESS STEEL BASE WITH ADJUSTABLE UNDERSHELF
- ADJUSTABLE BULLET FEET
- SHIPPED KNOCKED-DOWN, EASY-TO-ASSEMBLE
- NSF AND CSA CERTIFIED



ST4R5-3048SSK

#### **CONSTRUCTION:**

- TOP: STAINLESS STEEL TOPS ARE TIG WELDED, EXPOSED WELDS ARE POLISHED TO MATCH ADJACENT SURFACE.

#### **MATERIAL:**

- TOP: 14 GAUGE STAINLESS STEEL TYPE 300 STAINLESS STEEL WITH # 4 POLISH, SATIN FINISH
- SHELF: 18 GAUGE STAINLESS STEEL, (36" WIDE TABLES, 16 GAUGE LOWER SHELF)
- LEGS: 1-5/8" ROUND O.D. 16 GAUGE TUBULAR STAINLESS STEEL
- GUSSETS: STAINLESS STEEL
- FEET: 1" ADJUSTABLE STAINLESS BULLET FEET



ADJUSTABLE SHELF

#### **14 GAUGE TOP W/ ADJUSTABLE SHELF**

24" WIDE	QTY	30" WIDE	QTY	36" WIDE	QTY
ST4R5-2436SSK		ST4R5-3036SSK		ST4R5-3636SSK	
ST4R5-2448SSK		ST4R5-3048SSK		ST4R5-3648SSK	
ST4R5-2460SSK		ST4R5-3060SSK		ST4R5-3660SSK	
ST4R5-2472SSK		ST4R5-3072SSK		ST4R5-3672SSK	
ST4R5-2484SSK		ST4R5-3084SSK		ST4R5-3684SSK	
ST4R5-2496SSK		ST4R5-3096SSK		ST4R5-3696SSK	
ST4R5-24108SSK		ST4R5-30108SSK		ST4R5-36108SSK	
ST4R5-24120SSK		ST4R5-30120SSK		ST4R5-36120SSK	

#### **OPTIONAL ACCESSORIES**

DESCRIPTION	MODEL #	QTY
DRAWER		
DRAWER LOCK		
CASTERS		
OVERSHELVES		
SINKS		
POT RACK		

# DETAILED SPECIFICATIONS

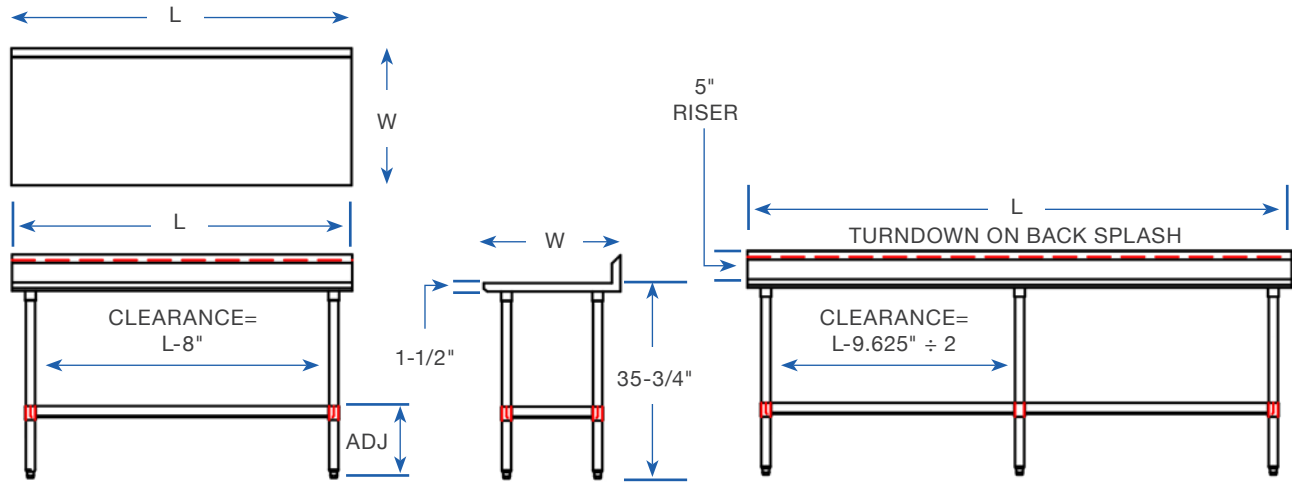

- UNITS 7 FT. AND LARGER ARE FURNISHED WITH SIX LEGS.
- FINISHED SIZE OF UNDERSHELF.  
 SHELF LENGTH = LENGTH MINUS 4.875"  
 SHELF WIDTH = WIDTH MINUS 4.25

## 14 GAUGE TOP W/ ADJUSTABLE UNDERSHELF

LENGTH	24" WIDE	WT. (LBS)	30" WIDE	WT. (LBS)	36" WIDE	WT. (LBS)
36"	ST4R5-2436SSK	62	ST4R5-3036SSK	70	ST4R5-3636SSK	86
48"	ST4R5-2448SSK	76	ST4R5-3048SSK	87	ST4R5-3648SSK	91
60"	ST4R5-2460SSK	91	ST4R5-3060SSK	118	ST4R5-3660SSK	107
72"	ST4R5-2472SSK	106	ST4R5-3072SSK	122	ST4R5-3672SSK	128
84"	ST4R5-2484SSK	125	ST4R5-3084SSK	130	ST4R5-3684SSK	151
96"	ST4R5-2496SSK	144	ST4R5-3096SSK	164	ST4R5-3696SSK	173
108"	ST4R5-24108SSK	159	ST4R5-30108SSK	182	ST4R5-36108SSK	192
120"	ST4R5-24120SSK	173	ST4R5-30120SSK	199	ST4R5-36120SSK	200

## MODEL # STRUCTURE

30 = WIDTH OF WORK SURFACE  
 5 = HT. OF RISER W/ TURNDOWN  
 R = RISER TOP WORK TABLE  
 4 = 14GA WORK SURFACE  
 ST = STAINLESS STEEL TOP

120 = LENGTH OF WORK SURFACE  
 SS = STAINLESS LEGS & SHELF  
 K = K.D. W/ ADJUSTABLE BRACING

# ST4R5-30120SSK

SOME UNITS SHIP UNASSEMBLED FOR REDUCED SHIPPING COST. ALL DIMENSIONS ARE TYPICAL. TOLERANCE +/- .500"  
 John Boos & Co. is constantly engaged in a program of improving products and therefore reserves the right to change specifications without prior notice.