



**John  
BOOS**  
Since 1887

ITEM #: \_\_\_\_\_ QTY: \_\_\_\_\_  
 MODEL #: \_\_\_\_\_  
 PROJECT NAME: \_\_\_\_\_

3601 S. Banker St. Effingham, IL 62401 • P.O. BOX 609 • Ph: (888) 431-2667 • Fax: (800) 433-2667

## **“ST6-GSK” STAINLESS STEEL TOP WORK TABLES**



### **16GA TOP AND GALV LEGS AND ADJUSTABLE UNDERSHELF**

#### **FEATURES:**

- 16 GAUGE STAINLESS STEEL TOP
- TYPE 300 STAINLESS STEEL WITH # 4 POLISH, SATIN FINISH
- TOP IS SOUND DEADENED
- REINFORCED WITH 1”X2” CHANNEL RUNNING ENTIRE LENGTH OF TABLE
- 1-1/2” STALLION EDGE ON FRONT AND REAR WITH SIDE EDGES
- 90 DEGREE BEND DOWN FOR TABLE LINE-UP
- GALVANIZED BASE WITH ADJUSTABLE UNDERSHELF
- SHIPPED KNOCKED-DOWN, EASY - TO - ASSEMBLE
- NSF AND CSA CERTIFIED



ST6-3048GSK

#### **CONSTRUCTION:**

- TOP: STAINLESS STEEL TOPS ARE TIG WELDED, EXPOSED WELDS ARE POLISHED TO MATCH ADJACENT SURFACE.

#### **MATERIAL:**

- TOP: 16 GAUGE STAINLESS STEEL TYPE 300 STAINLESS STEEL WITH # 4 POLISH, SATIN FINISH
- SHELF: 18 GAUGE STAINLESS STEEL, (36" WIDE TABLES, 16 GAUGE LOWER SHELF)
- LEGS: 1-5/8" ROUND O.D., 16 GAUGE TUBULAR GALVANIZED STEEL
- GUSSETS: GALVANIZED STEEL
- FEET: 1" ADJUSTABLE GALVANIZED BULLET FEET



ADJUSTABLE SHELF

#### **16 GAUGE TOP W/ ADJUSTABLE SHELF**

| 24" WIDE     | QTY | 30" WIDE     | QTY | 36" WIDE     | QTY |
|--------------|-----|--------------|-----|--------------|-----|
| ST6-2430GSK  |     | ST6-3030GSK  |     | -            |     |
| ST6-2436GSK  |     | ST6-3036GSK  |     | ST6-3636GSK  |     |
| ST6-2448GSK  |     | ST6-3048GSK  |     | ST6-3648GSK  |     |
| ST6-2460GSK  |     | ST6-3060GSK  |     | ST6-3660GSK  |     |
| ST6-2472GSK  |     | ST6-3072GSK  |     | ST6-3672GSK  |     |
| ST6-2484GSK  |     | ST6-3084GSK  |     | ST6-3684GSK  |     |
| ST6-2496GSK  |     | ST6-3096GSK  |     | ST6-3696GSK  |     |
| ST6-24108GSK |     | ST6-30108GSK |     | ST6-36108GSK |     |
| ST6-24120GSK |     | ST6-30120GSK |     | ST6-36120GSK |     |

#### **OPTIONAL ACCESSORIES**

| DESCRIPTION | MODEL # | QTY |
|-------------|---------|-----|
| DRAWER      |         |     |
| DRAWER LOCK |         |     |
| CASTERS     |         |     |
| OVERSHELVES |         |     |
| SINKS       |         |     |
| POT RACK    |         |     |

# DETAILED SPECIFICATIONS

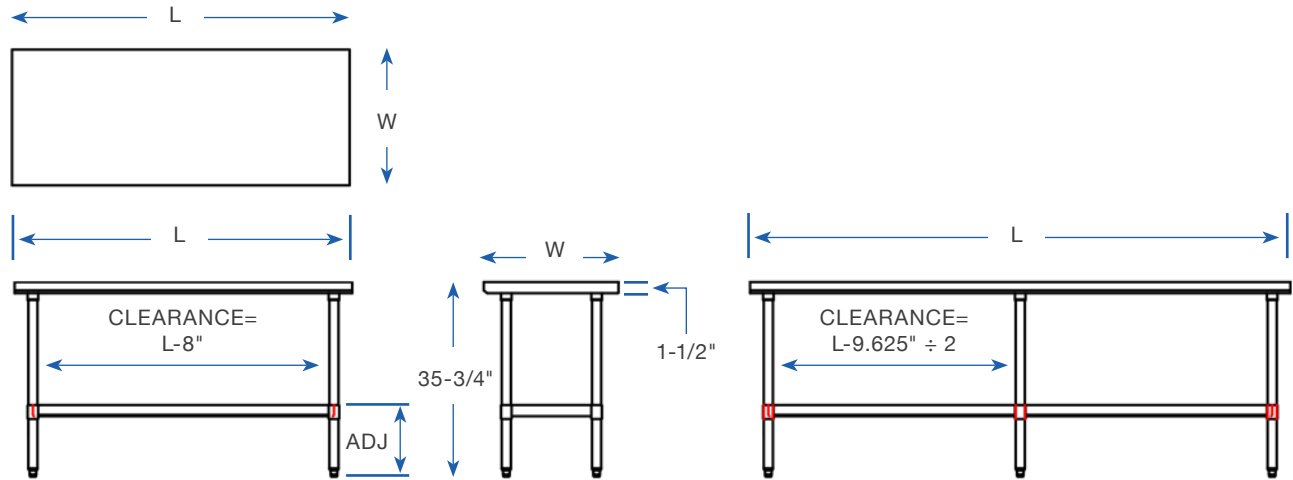

- UNITS 7 FT. AND LARGER ARE FURNISHED WITH SIX LEGS.
- FINISHED SIZE OF UNDERSHELF.  
 SHELF LENGTH = LENGTH MINUS 4.875"  
 SHELF WIDTH = WIDTH MINUS 4.25

## 16 GAUGE TOP W/ ADJUSTABLE SHELF

| LENGTH | 24" WIDE     | WT. (LBS) | 30" WIDE     | WT. (LBS) | 36" WIDE     | WT. (LBS) |
|--------|--------------|-----------|--------------|-----------|--------------|-----------|
| 30"    | ST6-2430GSK  | 39        | ST6-3030GSK  | 45        | -            | -         |
| 36"    | ST6-2436GSK  | 52        | ST6-3036GSK  | 59        | ST6-3636GSK  | 75        |
| 48"    | ST6-2448GSK  | 64        | ST6-3048GSK  | 76        | ST6-3648GSK  | 82        |
| 60"    | ST6-2460GSK  | 76        | ST6-3060GSK  | 92        | ST6-3660GSK  | 98        |
| 72"    | ST6-2472GSK  | 97        | ST6-3072GSK  | 111       | ST6-3672GSK  | 144       |
| 84"    | ST6-2484GSK  | 108       | ST6-3084GSK  | 125       | ST6-3684GSK  | 135       |
| 96"    | ST6-2496GSK  | 118       | ST6-3096GSK  | 139       | ST6-3696GSK  | 155       |
| 108"   | ST6-24108GSK | 130       | ST6-30108GSK | 153       | ST6-36108GSK | 171       |
| 120"   | ST6-24120GSK | 167       | ST6-30120GSK | 167       | ST6-36108GSK | 187       |
| 120"   | ST6-24120GSK |           | ST6-30120GSK |           | ST6-36120GSK |           |

## MODEL # STRUCTURE

30 = WIDTH OF WORK SURFACE  
 6 = 16GA WORK SURFACE  
 ST = STAINLESS STEEL TOP

120 = LENGTH OF WORK SURFACE  
 GS = GALVANIZED LEGS & SHELF  
 K = K.D. W/ ADJUSTABLE BRACING

**ST6-30120GSK**

SOME UNITS SHIP UNASSEMBLED FOR REDUCED SHIPPING COST. ALL DIMENSIONS ARE TYPICAL. TOLERANCE +/- .500"  
 John Boos & Co. is constantly engaged in a program of improving products and therefore reserves the right to change specifications without prior notice.