



**John  
BOOS**  
Since 1887

ITEM #: \_\_\_\_\_ QTY: \_\_\_\_\_  
 MODEL #: \_\_\_\_\_  
 PROJECT NAME: \_\_\_\_\_

3601 S. Banker St. Effingham, IL 62401 • P.O. BOX 609 • Ph: (888) 431-2667 • Fax: (800) 433-2667

## **"ST6R5-GSK" STAINLESS STEEL TOP WORK TABLES**

### **16GA TOP W/5" RISER AND GALV LEGS AND ADJUSTABLE UNDERSHELF**



#### **FEATURES:**

- 16 GAUGE STAINLESS STEEL TOP W/ 5" RISER & TURNDOWN
- TYPE 300 STAINLESS STEEL WITH # 4 POLISH, SATIN FINISH
- TOP IS SOUND DEADENED
- REINFORCED WITH 1"X2" CHANNEL RUNNING ENTIRE LENGTH OF TABLE
- 1-1/2" STALLION EDGE ON FRONT SIDE EDGES  
90 DEGREE BEND DOWN FOR TABLE LINE-UP
- GALVANIZED BASE WITH ADJUSTABLE UNDERSHELF
- SHIPPED KNOCKED-DOWN, EASY-TO-ASSEMBLE
- NSF AND CSA CERTIFIED



ST6R5-3048GSK

#### **CONSTRUCTION:**

- TOP: STAINLESS STEEL TOPS ARE TIG WELDED, EXPOSED WELDS ARE POLISHED TO MATCH ADJACENT SURFACE.

#### **MATERIAL:**

- TOP: 16 GAUGE STAINLESS STEEL TYPE 300 STAINLESS STEEL WITH # 4 POLISH, SATIN FINISH
- SHELF: 18 GAUGE GALVANIZED STEEL,  
(36" WIDE TABLES, 16 GAUGE LOWER SHELF)
- LEGS: 1-5/8" ROUND O.D. 16 GAUGE TUBULAR GALVANIZED STEEL
- GUSSETS: GALVANIZED STEEL
- FEET: 1" ADJUSTABLE GALVANIZED BULLET FEET



ADJUSTABLE SHELF

#### **16 GAUGE TOP W/ ADJUSTABLE SHELF**

24" WIDE	QTY	30" WIDE	QTY	36" WIDE	QTY
ST6R5-2430GSK		ST6R5-3030GSK		-	
ST6R5-2436GSK		ST6R5-3036GSK		ST4R5-3636GSK	
ST6R5-2448GSK		ST6R5-3048GSK		ST4R5-3648GSK	
ST6R5-2460GSK		ST6R5-3060GSK		ST4R5-3660GSK	
ST6R5-2472GSK		ST6R5-3072GSK		ST4R5-3672GSK	
ST6R5-2484GSK		ST6R5-3084GSK		ST4R5-3684GSK	
ST6R5-2496GSK		ST6R5-3096GSK		ST4R5-3696GSK	
ST6R5-24108GSK		ST6R5-30108GSK		ST4R5-36108GSK	
ST6R5-24120GSK		ST6R5-30120GSK		ST4R5-36120GSK	

#### **OPTIONAL ACCESSORIES**

DESCRIPTION	MODEL #	QTY
DRAWER		
DRAWER LOCK		
CASTERS		
OVERSHELVES		
SINKS		
POT RACK		

## DETAILED SPECIFICATIONS

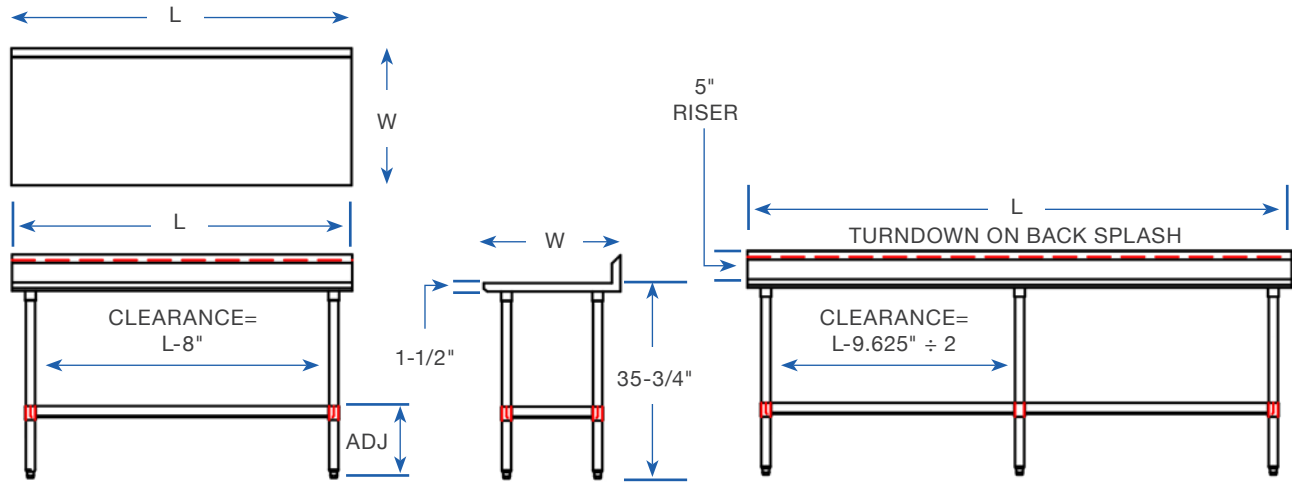

- UNITS 7 FT. AND LARGER ARE FURNISHED WITH SIX LEGS.
- FINISHED SIZE OF UNDERSHELF.  
 SHELF LENGTH = LENGTH MINUS 4.875"  
 SHELF WIDTH = WIDTH MINUS 4.25

### 16 GAUGE TOP W/ ADJUSTABLE UNDERSHELF

LENGTH	24" WIDE	WT. (LBS)	30" WIDE	WT. (LBS)	36" WIDE	WT. (LBS)
30"	ST6R5-2430GSK	43	ST6R5-3030GSK	45	-	-
36"	ST6R5-2436GSK	56	ST6R5-3036GSK	62	ST6R5-3636GSK	80
48"	ST6R5-2448GSK	67	ST6R5-3048GSK	79	ST6R5-3648GSK	87
60"	ST6R5-2460GSK	82	ST6R5-3060GSK	94	ST6R5-3660GSK	104
72"	ST6R5-2472GSK	95	ST6R5-3072GSK	121	ST6R5-3672GSK	122
84"	ST6R5-2484GSK	112	ST6R5-3084GSK	135	ST6R5-3684GSK	144
96"	ST6R5-2496GSK	129	ST6R5-3096GSK	149	ST6R5-3696GSK	165
108"	ST6R5-24108GSK	142	ST6R5-30108GSK	168	ST6R5-36108GSK	183
120"	ST6R5-24120GSK	155	ST6R5-30120GSK	180	ST6R5-36120GSK	200

## MODEL # STRUCTURE

30 = WIDTH OF WORK SURFACE  
 5 = HT. OF RISER W/ TURNDOWN  
 R = RISER TOP WORK TABLE  
 6 = 16GA WORK SURFACE  
 ST = STAINLESS STEEL TOP

120 = LENGTH OF WORK SURFACE  
 GS = GALVANIZED LEGS & SHELF  
 K = K.D. W/ ADJUSTABLE BRACING

# ST6R5-30120GSK

SOME UNITS SHIP UNASSEMBLED FOR REDUCED SHIPPING COST. ALL DIMENSIONS ARE TYPICAL. TOLERANCE +/- .500"  
 John Boos & Co. is constantly engaged in a program of improving products and therefore reserves the right to change specifications without prior notice.



3601 S. Banker St. • Effingham, IL 62401 • PO BOX 609 • quotes@johnboos.com



## www.johnboos.com