



**John
BOOS**
Since 1887

ITEM #: _____ QTY: _____
 MODEL #: _____
 PROJECT NAME: _____

3601 S. Banker St. Effingham, IL 62401 • P.O. BOX 609 • Ph: (888) 431-2667 • Fax: (800) 433-2667

"ST6R5-SBK" STAINLESS STEEL TOP WORK TABLES

16GA TOP W/5" RISER AND STAINLESS STEEL LEGS AND ADJUSTABLE BRACING



FEATURES:

- 16 GAUGE STAINLESS STEEL TOP W/ 5" RISER & TURNDOWN
- TYPE 300 STAINLESS STEEL WITH # 4 POLISH, SATIN FINISH
- TOP IS SOUND DEADENED
- REINFORCED WITH 1"X2" CHANNEL RUNNING ENTIRE LENGTH OF TABLE
- 1-1/2" STALLION EDGE ON FRONT SIDE EDGES
- 90 DEGREE BEND DOWN FOR TABLE LINE-UP
- STAINLESS STEEL BASE WITH ADJUSTABLE BRACING
- ADJUSTABLE BULLET FEET
- SHIPPED KNOCKED-DOWN, EASY-TO-ASSEMBLE
- NSF AND CSA CERTIFIED



ST6R5-3048SBK

CONSTRUCTION:

- TOP: STAINLESS STEEL TOPS ARE TIG WELDED, EXPOSED WELDS ARE POLISHED TO MATCH ADJACENT SURFACE.

MATERIAL:

- TOP: 16 GAUGE STAINLESS STEEL TYPE 300 STAINLESS STEEL WITH # 4 POLISH, SATIN FINISH
- BRACING: 1-1/4" ROUND O.D. 18 GAUGE STAINLESS STEEL
- LEGS: 1-5/8" ROUND O.D. 16 GAUGE TUBULAR STAINLESS STEEL
- GUSSETS: STAINLESS STEEL
- FEET: 1" ADJUSTABLE STAINLESS BULLET FEET



ADJUSTABLE BRACING

16 GAUGE TOP W/ ADJUSTABLE BRACING

24" WIDE	QTY	30" WIDE	QTY	36" WIDE	QTY
ST6R5-2430SBK		ST6R5-3030SBK		-	
ST6R5-2436SBK		ST6R5-3036SBK		ST6R5-3636SBK	
ST6R5-2448SBK		ST6R5-3048SBK		ST6R5-3648SBK	
ST6R5-2460SBK		ST6R5-3060SBK		ST6R5-3660SBK	
ST6R5-2472SBK		ST6R5-3072SBK		ST6R5-3672SBK	
ST6R5-2484SBK		ST6R5-3084SBK		ST6R5-3684SBK	
ST6R5-2496SBK		ST6R5-3096SBK		ST6R5-3696SBK	
ST6R5-24108SBK		ST6R5-30108SBK		ST6R5-36108SBK	
ST6R5-24120SBK		ST6R5-30120SBK		ST6R5-36120SBK	

OPTIONAL ACCESSORIES

DESCRIPTION	MODEL #	QTY
DRAWER		
DRAWER LOCK		
CASTERS		
OVERSHELVES		
SINKS		
POT RACK		

DETAILED SPECIFICATIONS

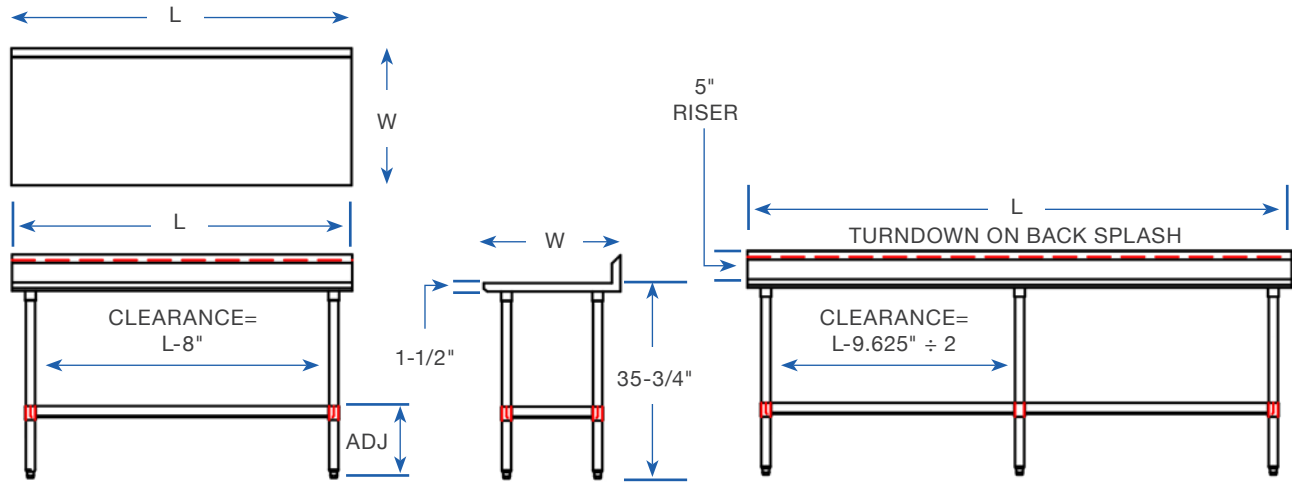

• UNITS 7 FT. AND LARGER ARE FURNISHED WITH SIX LEGS.

16 GAUGE TOP W/ ADJUSTABLE BRACING

LENGTH	24" WIDE	WT. (LBS)	30" WIDE	WT. (LBS)	36" WIDE	WT. (LBS)
30"	ST6R5-2430SBK	43	ST6R5-3030SBK	45	-	-
36"	ST6R5-2436SBK	49	ST6R5-3036SBK	53	ST6R5-3636SBK	65
48"	ST6R5-2448SBK	58	ST6R5-3048SBK	64	ST6R5-3648SBK	72
60"	ST6R5-2460SBK	69	ST6R5-3060SBK	76	ST6R5-3660SBK	80
72"	ST6R5-2472SBK	79	ST6R5-3072SBK	87	ST6R5-3672SBK	93
84"	ST6R5-2484SBK	93	ST6R5-3084SBK	103	ST6R5-3684SBK	110
96"	ST6R5-2496SBK	107	ST6R5-3096SBK	118	ST6R5-3696SBK	127
108"	ST6R5-24108SBK	117	ST6R5-30108SBK	130	ST6R5-36108SBK	139
120"	ST6R5-24120SBK	127	ST6R5-30120SBK	141	ST6R5-36120SBK	151

MODEL # STRUCTURE

30 = WIDTH OF WORK SURFACE
 5 = HT. OF RISER W/ TURNDOWN
 R = RISER TOP WORK TABLE
 6 = 16GA WORK SURFACE
 ST = STAINLESS STEEL TOP
 120 = LENGTH OF WORK SURFACE
 SB = STAINLESS LEGS & BRACING
 K = K.D. W/ ADJUSTABLE BRACING

ST6R5-30120SBK

SOME UNITS SHIP UNASSEMBLED FOR REDUCED SHIPPING COST. ALL DIMENSIONS ARE TYPICAL. TOLERANCE +/- .500"
 John Boos & Co. is constantly engaged in a program of improving products and therefore reserves the right to change specifications without prior notice.