



**John
BOOS**
Since 1887

ITEM #: _____ QTY: _____
 MODEL #: _____
 PROJECT NAME: _____

3601 S. Banker St. Effingham, IL 62401 • P.O. BOX 609 • Ph: (888) 431-2667 • Fax: (800) 433-2667

"ST6-SBK" STAINLESS STEEL TOP WORK TABLES

16GA TOP AND STAINLESS STEEL LEGS AND ADJUSTABLE BRACING



FEATURES:

- 16 GAUGE STAINLESS STEEL TOP
- TYPE 300 STAINLESS STEEL WITH # 4 POLISH, SATIN FINISH
- TOP IS SOUND DEADENED
- REINFORCED WITH 1"X2" CHANNEL RUNNING ENTIRE LENGTH OF TABLE
- 1-1/2" STALLION EDGE ON FRONT AND REAR WITH SIDE EDGES 90 DEGREE BEND DOWN FOR TABLE LINE-UP
- STAINLESS BASE WITH ADJUSTABLE BRACING
- ADJUSTABLE BULLET FEET
- SHIPPED KNOCKED-DOWN, EASY-TO-ASSEMBLE
- NSF AND CSA CERTIFIED



ST6-3048SBK

CONSTRUCTION:

- TOP: STAINLESS STEEL TOPS ARE TIG WELDED, EXPOSED WELDS ARE POLISHED TO MATCH ADJACENT SURFACE.

MATERIAL:

- TOP: 16 GAUGE STAINLESS STEEL TYPE 300 STAINLESS STEEL WITH # 4 POLISH, SATIN FINISH
- BRACING: 1-1/4" ROUND O.D. 18 GAUGE STAINLESS STEEL
- LEGS: 1-5/8" ROUND O.D., 16 GAUGE TUBULAR STAINLESS STEEL
- GUSSETS: STAINLESS STEEL
- FEET: 1" ADJUSTABLE STAINLESS BULLET FEET



ADJUSTABLE BRACING

16 GAUGE TOP W/ ADJUSTABLE BRACING

24" WIDE	QTY	30" WIDE	QTY	36" WIDE	QTY
ST6-2430SBK		ST6-3030SBK		-	
ST6-2436SBK		ST6-3036SBK		ST6-3636SBK	
ST6-2448SBK		ST6-3048SBK		ST6-3648SBK	
ST6-2460SBK		ST6-3060SBK		ST6-3660SBK	
ST6-2472SBK		ST6-3072SBK		ST6-3672SBK	
ST6-2484SBK		ST6-3084SBK		ST6-3684SBK	
ST6-2496SBK		ST6-3096SBK		ST6-3696SBK	
ST6-24108SBK		ST6-30108SBK		ST6-36108SBK	
ST6-24120SBK		ST6-30120SBK		ST6-36120SBK	

OPTIONAL ACCESSORIES

DESCRIPTION	MODEL #	QTY
DRAWER		
DRAWER LOCK		
CASTERS		
OVERSHELVES		
SINKS		
POT RACK		

DETAILED SPECIFICATIONS

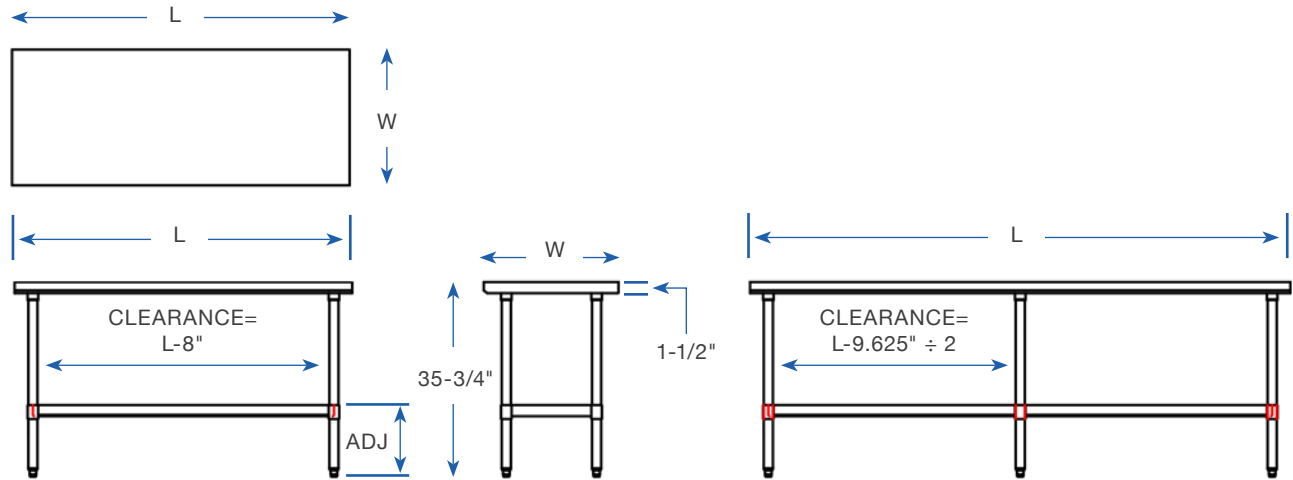

- UNITS 7 FT. AND LARGER ARE FURNISHED WITH SIX LEGS.

16 GAUGE TOP W/ ADJUSTABLE BRACING

LENGTH	24" WIDE	WT. (LBS)	30" WIDE	WT. (LBS)	36" WIDE	WT. (LBS)
30"	ST6-2430SBK	41	ST6-3030SBK	46	-	-
36"	ST6-2436SBK	46	ST6-3036SBK	50	ST6-3636SBK	60
48"	ST6-2448SBK	54	ST6-3048SBK	60	ST6-3648SBK	66
60"	ST6-2460SBK	63	ST6-3060SBK	70	ST6-3660SBK	77
72"	ST6-2472SBK	72	ST6-3072SBK	80	ST6-3672SBK	89
84"	ST6-2484SBK	85	ST6-3084SBK	94	ST6-3684SBK	104
96"	ST6-2496SBK	97	ST6-3096SBK	108	ST6-3696SBK	119
108"	ST6-24108SBK	106	ST6-30108SBK	118	ST6-36108SBK	130
120"	ST6-24120SBK	114	ST6-30120SBK	128	ST6-36120SBK	141

MODEL # STRUCTURE

30 = WIDTH OF WORK SURFACE
 6 = 16GA WORK SURFACE
 ST = STAINLESS STEEL TOP

120 = LENGTH OF WORK SURFACE
 SB = STAINLESS LEGS & BRACING
 K = K.D. W/ ADJUSTABLE BRACING

ST6-30120SBK

SOME UNITS SHIP UNASSEMBLED FOR REDUCED SHIPPING COST. ALL DIMENSIONS ARE TYPICAL. TOLERANCE +/- .500"
 John Boos & Co. is constantly engaged in a program of improving products and therefore reserves the right to change specifications without prior notice.

