



ITEM #: _____ QTY: _____
 MODEL #: _____
 PROJECT NAME: _____

3601 S. Banker St. Effingham, IL 62401 • P.O. BOX 609 • Ph: (888) 431-2667 • Fax: (800) 433-2667

"UFBLG" STAINLESS STEEL TOP WORK TABLES



18GA TOP W/1-1/2" REAR RISER AND GALV LEGS AND ADJUSTABLE UNDERSHELF
BUDGET E-SERIES

FEATURES:

- 18 GAUGE STAINLESS STEEL TOP W/1-1/2" REAR RISER
- TYPE 430 STAINLESS STEEL WITH SATIN FINISH
- TOP IS SOUND DEADENED
- REINFORCED WITH 1"X2" CHANNEL RUNNING ENTIRE LENGTH OF TABLE
- 1-1/2" STALLION EDGE ON FRONT AND REAR WITH SIDE EDGES 90 DEGREE BEND DOWN FOR TABLE LINE-UP
- GALVANIZED BASE AND ADJUSTABLE UNDERSHELF
- SHIPPED KNOCKED-DOWN, EASY-TO-ASSEMBLE
- NSF AND CSA CERTIFIED



UFBLG4830

CONSTRUCTION:

- TOP: STAINLESS STEEL TOPS ARE TIG WELDED, EXPOSED WELDS ARE POLISHED TO MATCH ADJACENT SURFACE.

MATERIAL:

- TOP: 18 GAUGE STAINLESS STEEL TYPE 430 STAINLESS STEEL WITH SATIN FINISH
- SHELF: 18 GAUGE GALVANIZED STEEL
- LEGS: 1-5/8" ROUND O.D. 16 GAUGE TUBULAR GALVANIZE STEEL
- GUSSETS: GALVANIZED STEEL
- FEET: 1" ADJUSTABLE PLASTIC BULLET FEET



ADJUSTABLE SHELF

18 GAUGE TOP W/ ADJUSTABLE SHELF

| 18" WIDE | QTY | 24" WIDE | QTY | 30" WIDE | QTY |
|-----------|-----|-----------|-----|-----------|-----|
| - | | UFBLG2424 | | - | |
| - | | UFBLG3024 | | UFBLG3030 | |
| UFBLG3618 | | UFBLG3624 | | UFBLG3630 | |
| UFBLG4818 | | UFBLG4824 | | UFBLG4830 | |
| UFBLG6018 | | UFBLG6024 | | UFBLG6030 | |
| UFBLG7218 | | UFBLG7224 | | UFBLG7230 | |
| UFBLG9618 | | UFBLG9624 | | UFBLG9630 | |

DETAILED SPECIFICATIONS

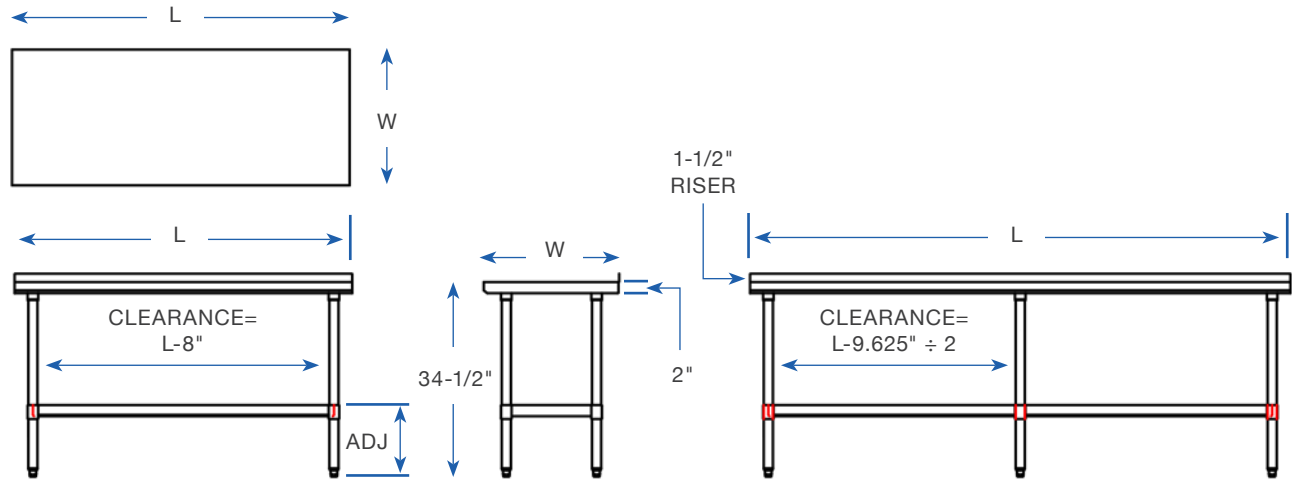

- UNITS 7 FT. AND LARGER ARE FURNISHED WITH SIX LEGS.
- FINISHED SIZE OF UNDERSHELF.
 SHELF LENGTH = LENGTH MINUS 4.875"
 SHELF WIDTH = WIDTH MINUS 4.25"

18 GAUGE TOP W/ ADJUSTABLE UNDERSHELF

| LENGTH | 18" WIDE | WT. (LBS) | 24" WIDE | WT. (LBS) | 30" WIDE | WT. (LBS) |
|--------|-----------|-----------|-----------|-----------|-----------|-----------|
| 24" | - | - | UFBLG2424 | 41 | - | - |
| 30" | - | - | UFBLG3024 | 46 | UFBLG3030 | 63 |
| 36" | UFBLG3618 | 48 | UFBLG3624 | 50 | UFBLG3630 | 56 |
| 48" | UFBLG4818 | 54 | UFBLG4824 | 60 | UFBLG4830 | 63 |
| 60" | UFBLG6018 | 61 | UFBLG6024 | 71 | UFBLG6030 | 82 |
| 72" | UFBLG7218 | 77 | UFBLG7224 | 80 | UFBLG7230 | 96 |
| 96" | UFBLG9618 | 94 | UFBLG9624 | 110 | UFBLG9630 | 129 |

SOME UNITS SHIP UNASSEMBLED FOR REDUCED SHIPPING COST. ALL DIMENSIONS ARE TYPICAL. TOLERANCE +/- .500"
 John Boos & Co. is constantly engaged in a program of improving products and therefore reserves the right to change specifications without prior notice.



3601 S. Banker St. • Effingham, IL 62401 • PO BOX 609 • quotes@johnboos.com

Boos
lock

AQ AutoQuotes

www.johnboos.com