



**John  
BOOS**  
Since 1887

ITEM #: \_\_\_\_\_ QTY: \_\_\_\_\_

MODEL #: \_\_\_\_\_

PROJECT NAME: \_\_\_\_\_

3601 S. Banker St. Effingham, IL 62401 • P.O. BOX 609 • Ph: (888) 431-2667 • Fax: (800) 433-2667

## PRO-BOWL DROP-IN HAND SINK



### 1 BOWL

#### FEATURES:

- ONE PIECE DEEP DRAWN BOWL
- ALL SINK BOWLS HAVE LARGE LIBERAL RADII CORNERS
- INCLUDES BASKET DRAIN
- DECK MOUNT FAUCET HOLES - 4" ON-CENTER

#### CONSTRUCTION:

- BOWL: STAINLESS STEEL TOPS ARE TIG WELDED, EXPOSED WELDS ARE POLISHED TO MATCH ADJACENT SURFACE.

#### MATERIAL:

- BOWL: TYPE 300 STAINLESS STEEL POLISH, SATIN FINISH
- BRACKET: TYPE 300 STAINLESS STEEL POLISH, SATIN FINISH



SK01



PB-DISINK090905

### PRO-BOWL DROP-IN HAND SINKS

MODEL #	QTY
SK01	
PB-DISINK090905	

**\*\*CALL FACTORY FOR CUT OUT SIZES.\*\***

### OPTIONAL ACCESSORIES

DESCRIPTION	QTY
FAUCETS	
SIDE SPASH	
ADA WRIST BLADES	
TOWEL DISPENSER	
LEVER WASTES	
OVER FLOWS	
P-TRAPS	

# PRO-BOWL DROP-IN HAND SINKS DETAILED SPECIFICATIONS

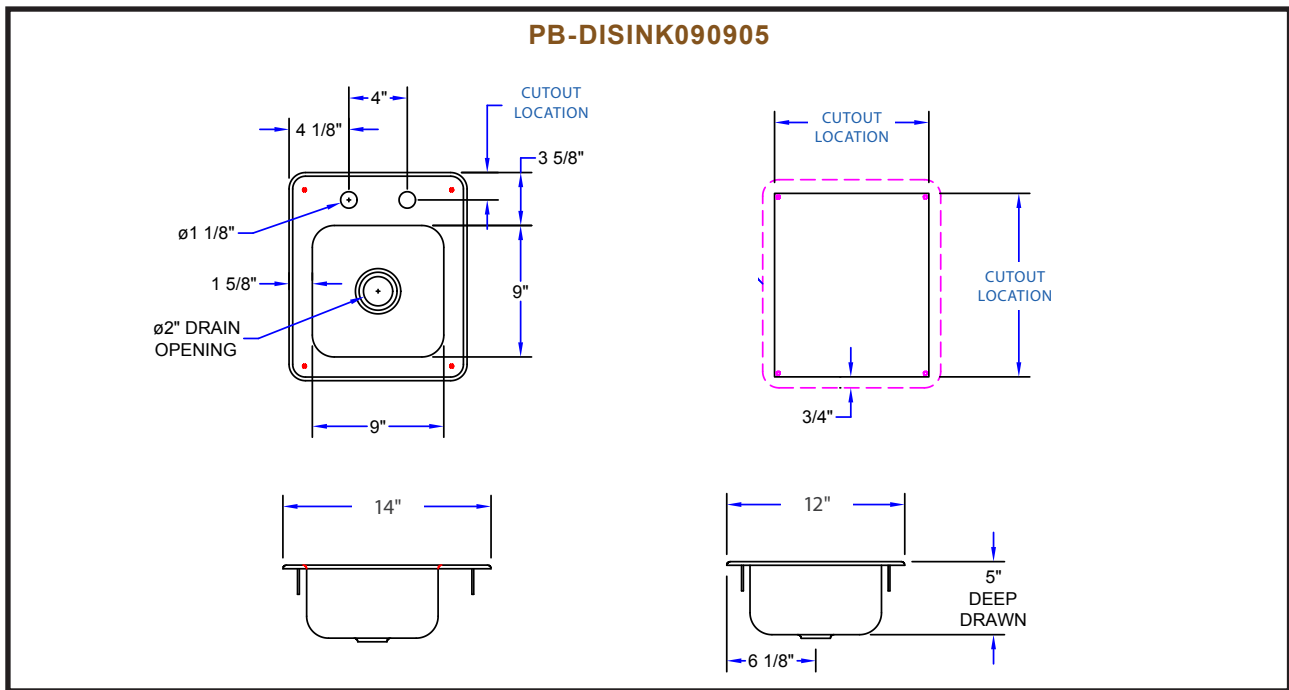
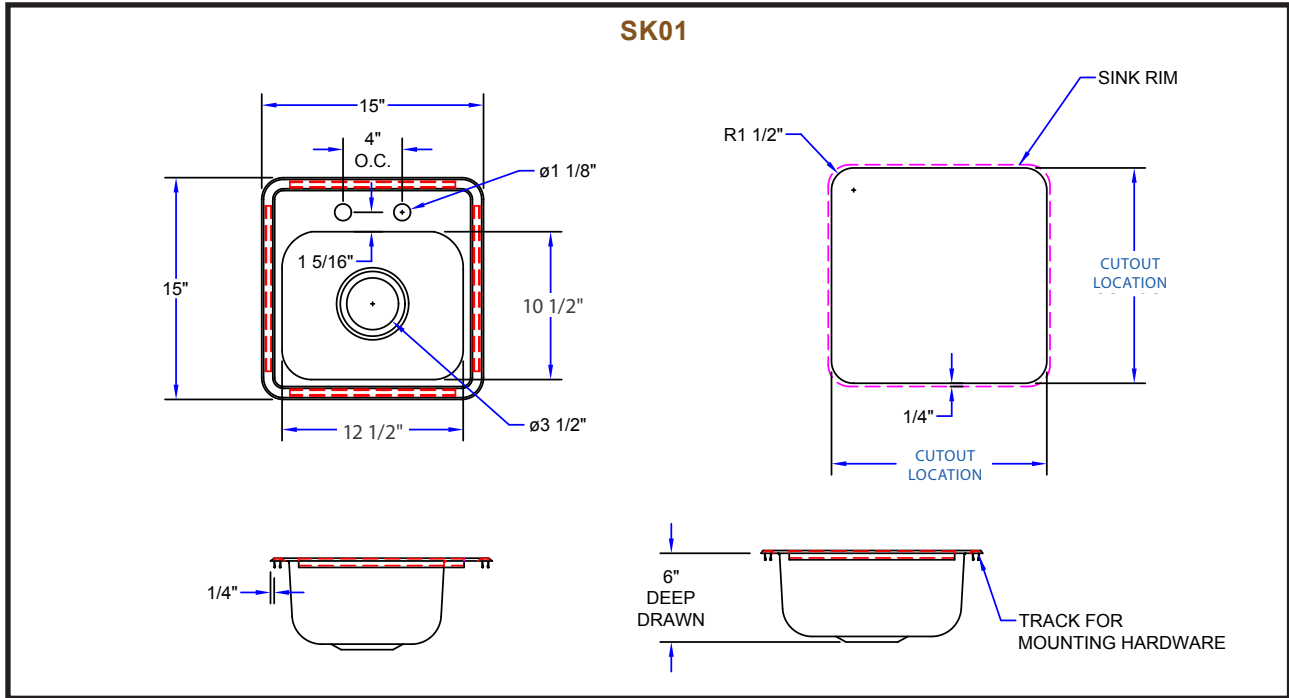

## PRO-BOWL DROP-IN HAND SINKS

MODEL #	BOWL SIZE (LxWxD)	SINK SIZE (LxWxD)	CERTIFICATION	SIDE SPLASH
SK01	12-1/2" X 10-1/2" X 6"	15" X 15" X 6"	NSF COMPONENT	N/A
PB-DISINK090905	9" X 9" X 5"	12" X 14" X 5"	NSF COMPONENT	N/A

**\*\*CALL FACTORY FOR CUT OUT SIZES.\*\*** WEIGHTS ARE SUBJECT TO ADDITIONAL PACKAGING

SOME UNITS SHIP UNASSEMBLED FOR REDUCED SHIPPING COST. ALL DIMENSIONS ARE TYPICAL. TOLERANCE +/- .500"  
John Boos & Co. is constantly engaged in a program of improving products and therefore reserves the right to change specifications without prior notice.