

Project \_\_\_\_\_  
 Item \_\_\_\_\_  
 Quantity \_\_\_\_\_  
 CSI Section 11400 \_\_\_\_\_  
 Approval \_\_\_\_\_  
 Date \_\_\_\_\_

# Conserver® XL2

## Models

- Conserver® XL2     Conserver® XL2-CMR     Conserver® XL2-CML



### Standard Features

- Electromechanical timer
- Built in waste accumulator
- 3" (76mm) stainless steel adjustable bullet feet
- Delimer switch for easy removal of hard water deposits
- Removable scrap screen
- Air gap instead of vacuum breaker
- Door switch
- Convenient top mounted controls
- Auto start
- Interchangeable upper and lower stainless steel wash/rinse arms
- Internal sump saves space
- Wash/rinse thermometer
- Low product indicator light

### Mandatory Specs

- Specify voltage \_\_\_\_\_

### Options

- 50Hz Cycle
- Water Hammer Arrestor
- Scaltrol
- Flanged Feet
- Audible Low Product Alarm

### Accessories

- 36-Compartment Rack
  - 4-1/8" tall (105 mm)
  - 5-5/8" tall (143 mm)
  - 7" tall (178 mm)
- Combination Rack
- Peg Rack

## Specifications

Uses 1.17 gallons (4.43 liters) of water per rack

74 racks per hour

Single point electrical connection

Self-draining stainless steel pump eliminates soil/detergent carryover between wash and rinse cycles

Dump and fill feature disposes of dirty water, replacing it with a fresh water rinse every cycle

Dual-point drain connections allow for versatile installations

17-1/4" (438mm) vertical inside clearance

Built-in chemical pumps and priming switches

Accommodates two racks side by side

Durable stainless steel construction



**Intertek**



# Conserver® XL2

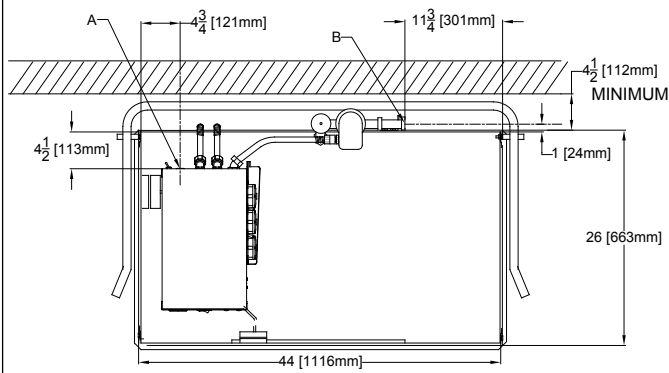

## LEGEND

- A - ELECTRICAL CONNECTION
- B - WATER INLET, 3/4" IPS
- C - DRAIN CONNECTION, 2" IPS

ALL DIMENSIONS ARE +/- 1/2" FROM FLOOR DUE TO ADJUSTABLE BULLET FEET.

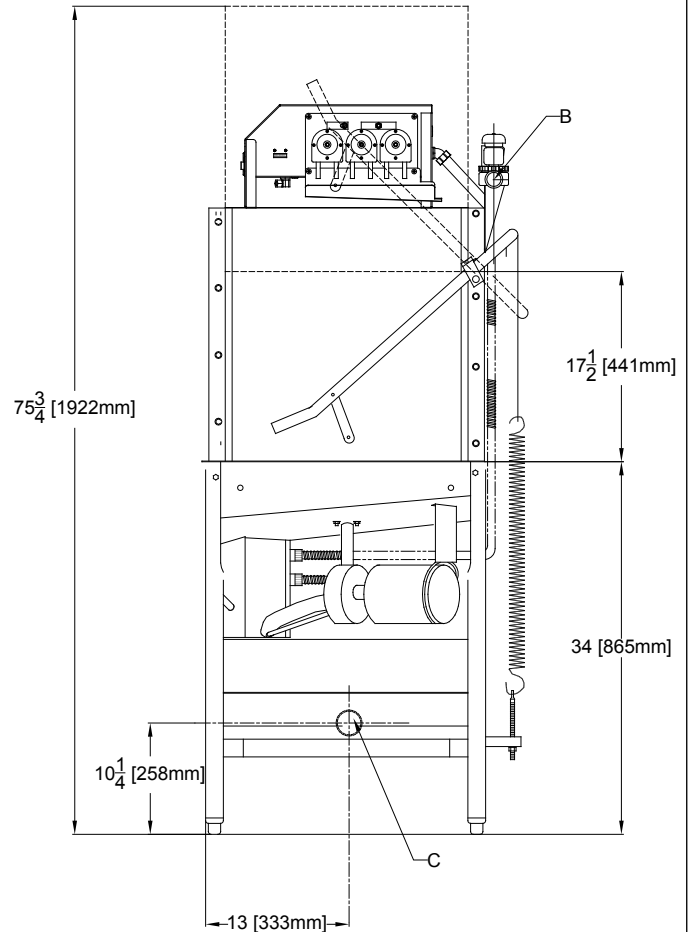
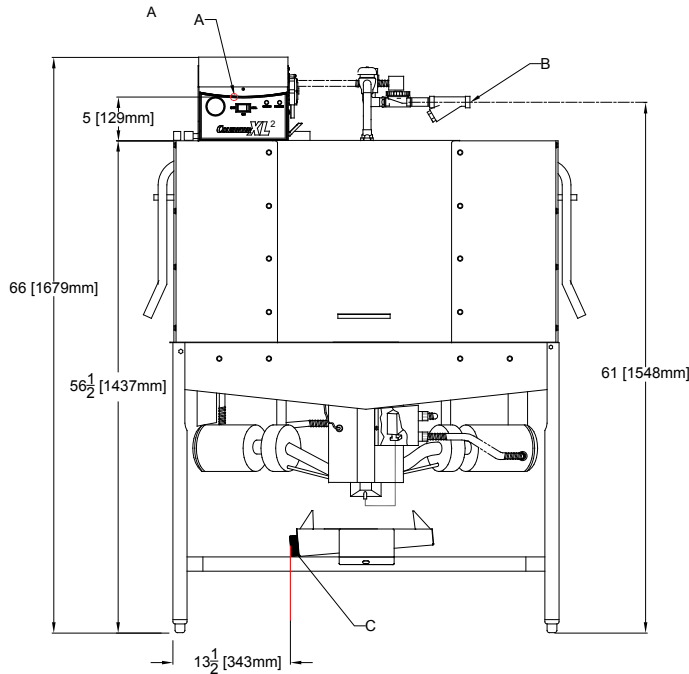

## POWER REQUIREMENTS

MODEL NO.	ELECTRICAL REQUIREMENT	SERVICE BREAKER SIZE
Conserver® XL2	115v/60~1ø-22.8A	30A

## WATER REQUIREMENTS

	MINIMUM	RECOMMENDED
Inlet Temperature	120°F 48.9°C	140°F 60°C
Wash Operating Temperatures	120°F 48.9°C	140°F 60°C
Rinse Operating Temperatures	120°F 48.9°C	140°F 60°C

## PERFORMANCE CAPABILITIES

Flow Pressure (PSI)	15-25
Wash Pump Motor Horsepower	1
Pump Capacity (GPM)	55
Minimum Chlorine Required (PPM)	50

MODEL NO.	MACHINE DIMENSIONS			DRAIN HEIGHT	SHIPPING INFORMATION					
	HEIGHT	WIDTH	DEPTH		WEIGHT	CLASS	CUBE	HEIGHT	WIDTH	DEPTH
Conserver® XL2	68-1/2" (1740 mm)	50-1/2" (1286 mm)	25" (635 mm)	11-1/4" (283 mm)	560 lbs (254 kg)	92.5	74.5 cu. ft.	78" (1981 mm)	55" (1397 mm)	30" (762 mm)

HOW TO SPECIFY: Conserver® XL2

## LEGEND

- A - ELECTRICAL CONNECTION
- B - WATER INLET, 3/4" IPS
- C - DRAIN CONNECTION, 2" IPS

ALL DIMENSIONS ARE +/- 1/2"  
FROM FLOOR DUE TO  
ADJUSTABLE BULLET FEET.

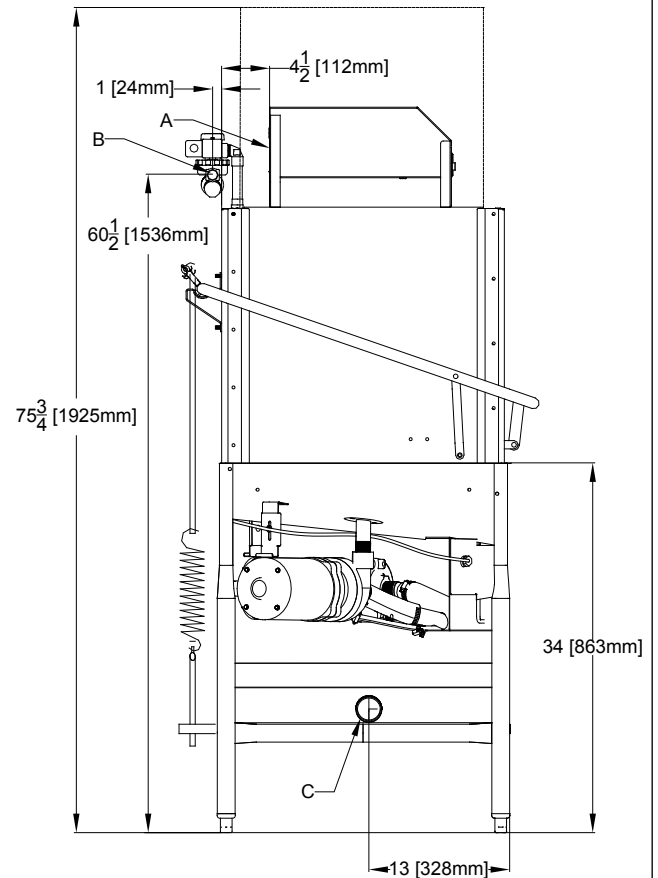
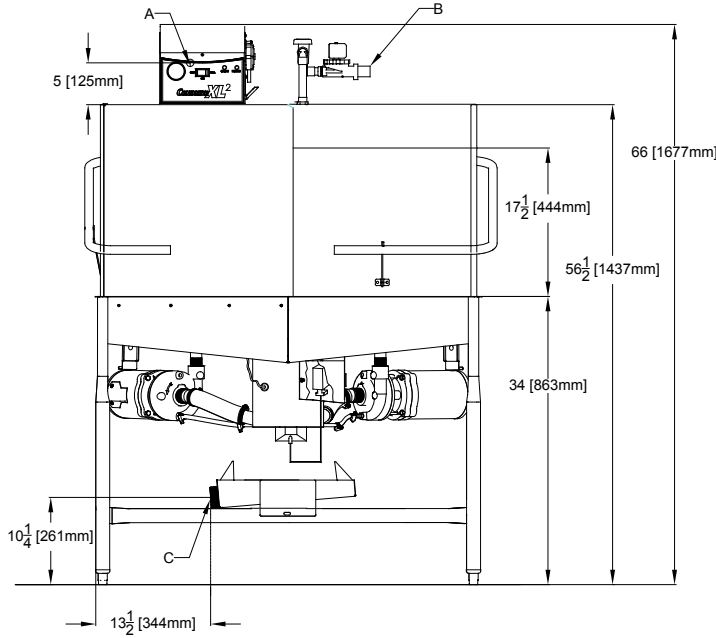
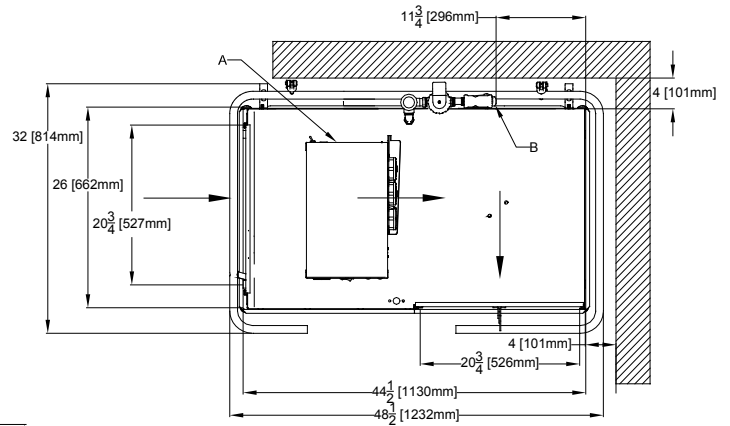

## POWER REQUIREMENTS

MODEL NO.	ELECTRICAL REQUIREMENT	SERVICE BREAKER SIZE
Conserver® XL2-CMR	115v/60~1ø-22.8A	30A

## WATER REQUIREMENTS

	MINIMUM	RECOMMENDED
Inlet Temperature	120°F 49°C	140°F 60°C
Wash Operating Temperatures	120°F 49°C	140°F 60°C
Rinse Operating Temperatures	120°F 49°C	140°F 60°C

## PERFORMANCE CAPABILITIES

Flow Pressure (PSI)	15-25
Wash Pump Motor Horsepower	1
Pump Capacity (GPM)	55
Minimum Chlorine Required (PPM)	50

MODEL NO.	MACHINE DIMENSIONS			DRAIN HEIGHT	SHIPPING INFORMATION					
	HEIGHT	WIDTH	DEPTH		WEIGHT	CLASS	CUBE	HEIGHT	WIDTH	DEPTH
Conserver® XL2-CMR	68-1/2" (1740 mm)	48-1/2" (1232 mm)	25" (635 mm)	11-1/4" (283 mm)	560 lbs (254 kg)	92.5	74.5 cu. ft.	78" (1981 mm)	55" (1397 mm)	30" (762 mm)

HOW TO SPECIFY: Conserver® XL2-CMR

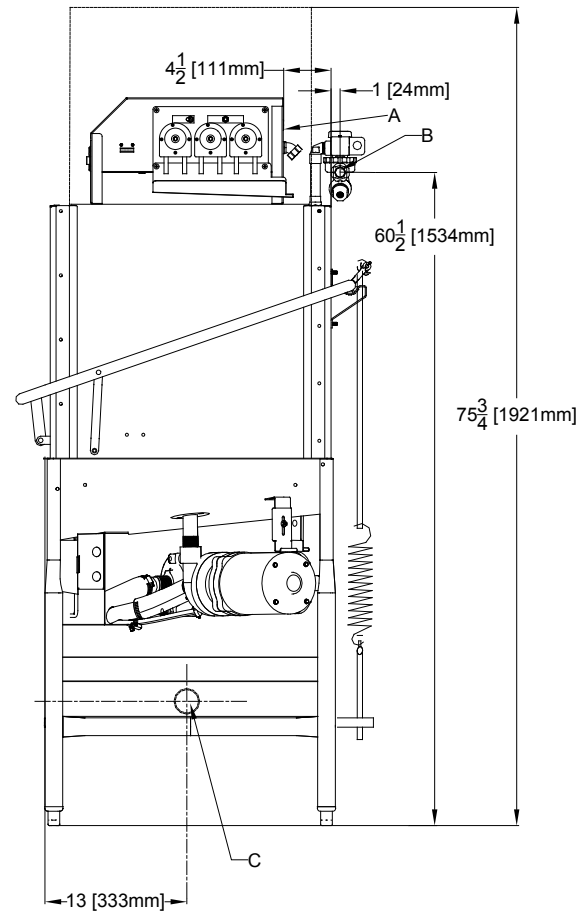
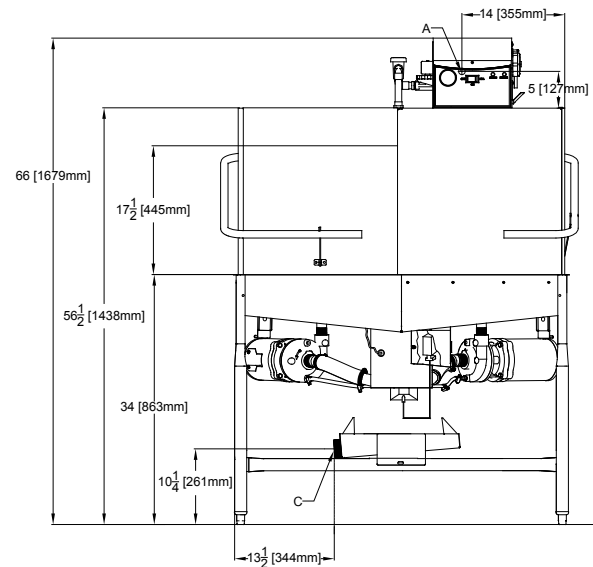
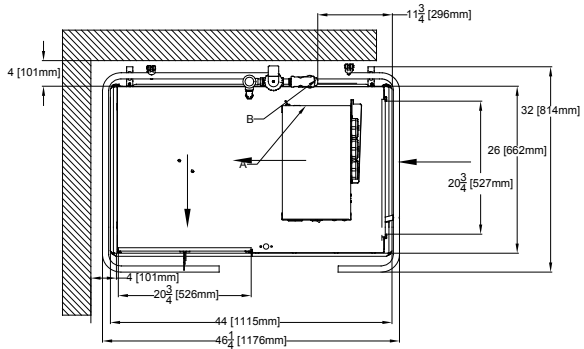

### LEGEND

- A - ELECTRICAL CONNECTION
- B - WATER INLET, 3/4" IPS
- C - DRAIN CONNECTION, 2" IPS

ALL DIMENSIONS ARE +/- 1/2" FROM FLOOR DUE TO ADJUSTABLE BULLET FEET.

POWER REQUIREMENTS		
MODEL NO.	ELECTRICAL REQUIREMENT	SERVICE BREAKER SIZE
Conservor® XL2-CML	115v/60~1ø-22.8A	30A

WATER REQUIREMENTS		
	MINIMUM	RECOMMENDED
Inlet Temperature	120°F 49°C	140°F 60°C
Wash Operating Temperatures	120°F 49°C	140°F 60°C
Rinse Operating Temperatures	120°F 49°C	140°F 60°C

PERFORMANCE CAPABILITIES	
Flow Pressure(PSI)	15-25
Wash Pump Motor Horsepower	1
Pump Capacity (GPM)	55
Minimum Chlorine Required (PPM)	50

MODEL NO.	MACHINE DIMENSIONS			DRAIN HEIGHT	SHIPPING INFORMATION					
	HEIGHT	WIDTH	DEPTH		WEIGHT	CLASS	CUBE	HEIGHT	WIDTH	DEPTH
Conservor® XL2-CML	68-1/2" (1740 mm)	48-1/2" (1232 mm)	25" (635 mm)	12" (305 mm)	560 lbs (254 kg)	92.5	74.5 cu. ft.	78" (1981 mm)	55" (1397 mm)	30" (762 mm)

HOW TO SPECIFY: Conservor® XL2-CML

### Jackson WWS, Inc.

Shipping Address: 6209 North U.S. Highway 25E, Gray, KY 40734  
 Mailing Address: P.O. Box 1060, Barbourville, KY 40906  
 Telephone: 888-800-5672 • Fax: 606-523-1799  
 Email: info@jacksonwws.com  
 07610-002-66-64 [02/26/16]

[www.jacksonwws.com](http://www.jacksonwws.com)