



Features:

- Enclosed aluminum cabinet with solid pass through doors that open 270 degrees
- Ergonomic push handle
- Perimeter bumpers for fixture & wall protection
- Drain holes in base for easier internal cleaning
- 1" x 5" tray supports on removable inner panels
- Tray supports on 5 1/2" centers

Options:

- 5" wide "C" channel tray supports
- Caster options available



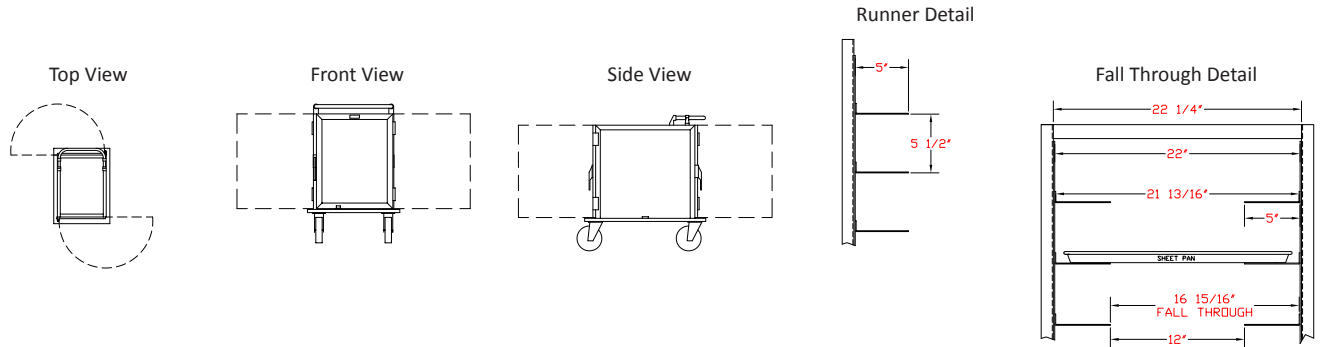

Lockwood Model No.	Pan			Exterior Dimensions			Inside Dimensions				Weight
	Angles	Capacity		Width	Depth	Height	Width	Depth	Height		
CA36-RR5-PT-6PS	5 pair	10	IN	29	39	41 1/4	21 13/16	32	28 1/2	LBS	101
			CM	73.66	99.06	104.78	55.39	81.28	72.39	KG	45.81

Cabinet Specifications:

- Top: One piece .063" aluminum; riveted and welded to sides and back
- Side panels: Formed .080" aluminum; welded to base and top
- Back panel: .080" aluminum; welded and riveted to base and top
- Frame: .25" wall, 1.5" square tube

Tray Sizes Supported:

- 14" x 18"
- 15" x 20"
- 15 1/4" x 20 1/2"

Base Specifications:

- One piece .125" aluminum; formed construction
- Casters: (2) 6" x 2" Performa quiet tread swivel with precision bearings and brakes; (2) 6"x2" rigid Performa quiet casters; load capacity 675 lbs each

Door Specifications:

- Frame: 7/8" x 1 3/4" extruded aluminum screwed and welded together
- Panel: .063" solid aluminum sheet, fitted into door frame
- Latch: Magnetic type latch handle screwed to door frame
- Hinges: 4" stainless steel - opens 270°
- Gasket: Perimeter; fitted into frame extrusion, flexible PVC rubber

Lockwood reserves the right to change materials and specifications without notice.

Pan Support Specifications:

- Extruded .090" aluminum
- Welded to removable inner panels