

CA74-PFIN-PT

Insulated Pass-Thru Hot-Stor Cabinet

CHOOSE YOUR DOOR CONFIGURATION

- Door configurations include clear polycarbonate and solid insulated aluminum in both full length and Dutch Door options
- Furnished with 16 pair of 5" wide removable pan supports for sheet pans or steam table pans

Additional Features:

- Digital thermometer
- Temperature adjustable to approximately 180° F
- Exterior mounted controls
- Easy to use heat unit with separate temperature and humidity controls
- Removable heat unit for easy maintenance and repair
- Blower fan provides uniform heat distribution throughout cabinet
- Integrated side handles
- Standard with right hand hinging; left hand hinging available upon request

Options:

- 3-1/2" or 5-1/2" wide pan supports
- Perimeter or corner bumpers
- Hasp lock
- Additional caster options available





CA74-PFIN-PT
Insulated Pass Thru Hot-Stor Cabinet

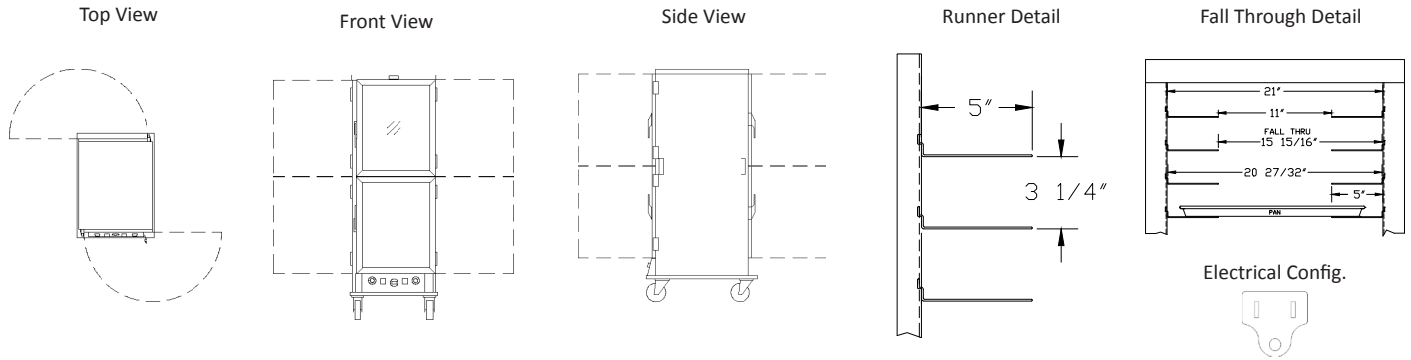

Lockwood Model No.	Pan			Exterior Dimensions			Inside Dimensions				Weight
	Tray Size	Capacity		Width	Depth	Height	Width	Depth	Height		
CA74-PFIN-PT	18x26	16	IN	26 7/8	36	75 3/8	20 11/32	30 1/8	59 1/8	LBS	270
	12x20x2.5	32	CM	68.28	91.44	191.47	51.66	76.52	150.18	KG	122.47

** Add 2" to width and depth with corner bumper option

Cabinet Specifications:

- Top: One piece .063" aluminum; riveted to sides
- Side panels: Formed .090" aluminum; welded to base and riveted to top

Base Specifications:

- One piece .125" aluminum; formed construction
- Casters: (4) 6" x 2" polyurethane swivel (2 w/brakes); load capacity 720 lbs each (408.23 kg); temp. range -45 °/ +180° F

Door Specifications:

- Frame: 7/8" x 1 3/4" extruded aluminum screwed and welded together
- Panel: .118" clear polycarbonate or .063" aluminum inner and outer sheet with 1/2" thick insulation fitted into door frame
- Latch: Magnetic type latch handle screwed to door frame
- Hinges: 4" stainless steel - opens 180°
- Flexible compression gasket: Perimeter; fitted into frame extrusion

Pan Support Specifications:

- Extruded .080" aluminum; removable; 5" wide standard
- 16 pair adjustable on 3 1/4" centers

Heat Unit Specifications:

- Removable bottom mount proof / hold unit
- Body: Formed .063" aluminum
- Thermostat (holding): Mechanical, up to 195°
- Thermostat (humidity): Mechanical, up to 95%
- Indicator lights: Power, Proof, Hold modes
- Switches: (2) Rocker type with guards
- Heat Elements: (1) 1000 W, (1) 500 W internal; (1) 1000 W immersible external for proofing
- Blower Motor
- Thermometer
- Water Pan: 4.3 quart, 23 ga., 18/8 stainless steel

Power Requirements:

- 1500 Watts, 120 Volts, 60 Hz, Single Phase 15 Amp.
- Dedicated 15 Amp. service.

Lockwood reserves the right to change materials and specifications without notice.