

**E****UNIVERSE PLUS  
ELECTRIC TILTING SKILLET**

JOB NAME: \_\_\_\_\_

ITEM NO.: \_\_\_\_\_

NO. REQUIRED: \_\_\_\_\_

**MODELS**

- 30P-STEL** - 30 gallon (114 liter), open leg base skillet
- 30P-STEM** - 30 gallon (114 liter), closed base skillet
- 40P-STEL** - 40 gallon (152 liter), open leg base skillet
- 40P-STEM** - 40 gallon (152 liter), closed base skillet

**DESCRIPTION**

The Market Forge electric Universe Plus tilting skillets are available in 30-gallon (114-liter), 12kW and 40-gallon (152-liter), 18 kW pans. Both models are available in open-leg and closed-base frame assemblies with manual or power tilt capabilities.

Pan is formed from 10 gauge T-304 stainless steel with a #4 finish exterior and polished interior with covered corners for ease of cleaning. Heating shall be accomplished by electric elements cast embedded in a full 1-3/8" (35 mm) thick aluminum casting bolted to the underside of the pan for even heat distribution across the entire surface. Units are equipped with (4) 6" (152mm) stainless steel adjustable flanged feet as standard. The balanced design allows the operator to easily and quickly tilt to the desired position. Our new power tilt operates smoothly, with manual override that works easily when needed without the use of tools or drills as required by other manufactures.

**CONSTRUCTION**

Universe Plus skillets have a fully polished stainless steel cooking surface that is easy to clean and prevents food from adhering. Heaters turn off automatically when the cooking pan is tilted from the horizontal position. The skillet is provided with a heavy-duty spring assisted cover with a condensate vent. The cooking pan and cover are supported by two consoles with a fully welded stainless steel tubular frame system that provides stable support to the unit.

The consoles are completely covered with stainless steel that provides protection to the controls and is also easily cleanable and provides clear access for easy floor cleaning. The closed-base model incorporates an easily removable stainless steel front and rear panel. The sloped front of the pan allows for complete draining of the pan when tilted to 70°. The tilting mechanism includes a precision ground and polished worm for smooth and long lasting tilt operation and positive control with a collapsible hand crank. A power tilting option is available and is also supplied with the collapsible handle for manual override operation if required.

**SHIPPING WEIGHT**

- **30P-STEL** - 515 lbs (234 kg)
- **30P-STEM** - 545 lbs (247 kg)
- **40P-STEL** - 630 lbs (286 kg)
- **40P-STEM** - 660 lbs (299 kg)



30P-STEM shown



30P-STEL shown

**OPTIONS & ACCESSORIES**

(at additional charge)

■ **Pantry Faucets**

- Double Pantry Faucet
- Single Pantry Faucet
- Single Pantry Spray Hose
- Double Pantry Spray Hose
- Single Pantry Faucet / with 60" Spray Hose
- Double Pantry Faucet / with 60" Spray Hose

■ **Tangent Draw-Off**

- 2" Draw-Off Valve w/Strainer
- 2" Tangent Draw-Off Valve w/ Drain Hose Assembly
- Power Tilt
- Pan Support
- Pan Holder Inserts
- Pouring Lip Strainer
- Caster Kit w/Strain Relief
- Prison package, includes lockable stainless steel hinged control cover, tamper proof screws
- Drain Cup Assembly
- Drain Pan Assembly (Requires Pan Support Option)
- Pull-Out Sliding Sink Drain Draw with Splash Shield for Open Leg Skillets

**FOOD SERVICE EQUIPMENT**  
 Universe Plus Tilting Skillet

**MARKET FORGE**  
 INDUSTRIES INC.

**E****UNIVERSE PLUS  
ELECTRIC TILTING SKILLET**

DETAILS &amp; DIMENSIONS

**TECHNICAL SPECIFICATIONS**

**COOKING PAN:** The polished cooking surface resists product adherence and improves cleanup and appearance. The pan incorporates an easy-pour lip and 5-gallon increment markings. An interlock switch is provided to turn the heaters off when the pan is tilted more than 10° from the normal horizontal position. The spring assisted cover with integral vent, condensate drip guide and full width handle affords effortless operation and will maintain an open position.

**CONTROLS:** The skillet comes standard with a solid-state temperature control with a positive OFF position and 100-450°F scale, a pilot light to indicate when the elements are ON, and a 1 hour mechanical timer. The optional power tilting mechanism also utilizes an UP/DOWN rocker switch. The manual tilting mechanism uses a collapsible hand crank conveniently located below the control panel. The controls are resistant to dripping and light splashing water (NEMA T-2).

**OPERATION SHALL BE BY**

All Universe Plus tilting skillets models are available in 208VAC, 240VAC, field convertible to 1 or 3 phase, or 480VAC 3 phase. 30 gallon models are rated at 12 kW and the 40 gallon models are rated at 18 kW.

**ELECTRICAL CHARACTERISTICS**

	40 gallon models (18 kW)		30 gallon models (12 kW)	
VAC	1 pH	3 pH	1 pH	3 pH
208	87	50	58	33
240	75	43	50	29
480	--	22	--	14.5

Details of other electrical systems are available upon request.

**SERVICE CONNECTIONS**

<b>E</b>	<b>Electrical Connection</b> - Use wire suitable for 90°C. A stepdown transformer provides power to the 120V control circuit.
<b>CW</b>	<b>Cold Water</b> - 3/8" O.D. NPT to faucet (Optional).
<b>HW</b>	<b>Hot Water</b> - 3/8" O.D. NPT to faucet (Optional).
<b>D</b>	<b>Drain</b> - 1-1/2" drain NPT (Optional)

**INSTALLATION CLEARANCE**

Left Side	Right Side	Rear
0	0	10" [254mm]

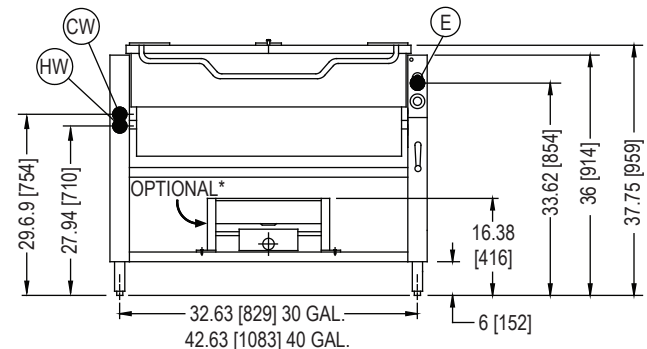
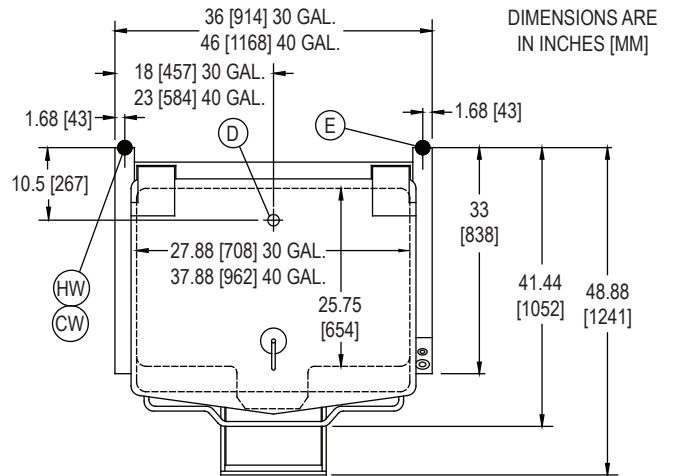

\*OPTIONAL: Pull out sliding sink drain draw with splash shield for open leg skillets

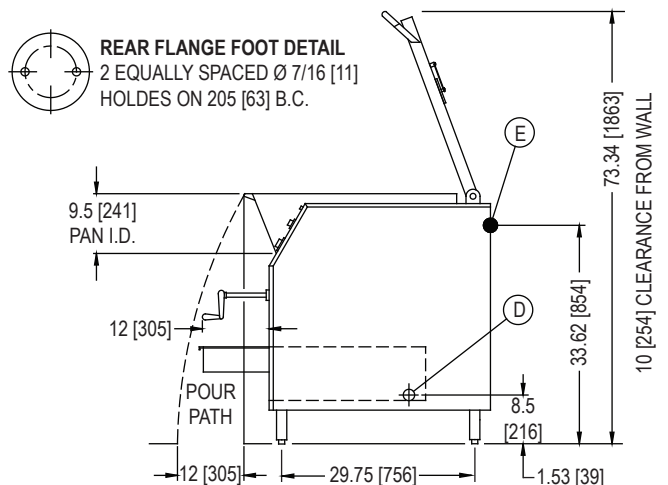

The manufacturer reserves the right to modify materials and specifications without notice.

**FOOD SERVICE EQUIPMENT**  
Universe Plus Tilting Skillet

PRINTED IN U. S. A.  
SPEC SHEET: 14-0228 Rev B (3/15)

AutoQuotes

**MARKET FORGE**  
INDUSTRIES INC.

44 Lakeside Avenue, Burlington, VT 05401 USA • Tel: (802) 658-6600 • Fax: (802) 864-0183  
www.mfii.com