



Profit from the Eagle Advantage®

Specification Sheet

Short Form Specifications

Eagle Spec-Master® Prep Table, model _____. Top is 14/304 stainless steel with front rolled edge and sides turned down 90°, stainless steel undershelf, and 4½"-high stainless steel backsplash. 16" x 19" x 8" stainless steel deep-drawn sink with deck mounted faucet and polymer cover. 20" x 20" x 5" stainless steel drawer. 1½" O.D. stainless steel tubular legs with adjustable stainless steel bullet feet.



prep table

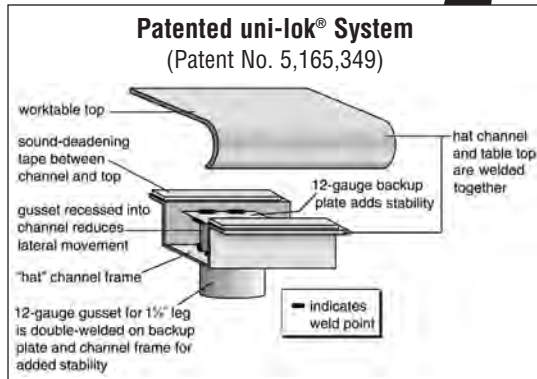

Item No.: _____
 Project No.: _____
 S.I.S. No.: _____

Spec-Master® Prep Tables

MODELS:

- PT 3072
- PT 3072-R
- PT 3084
- PT 3084-R
- PT 3096
- PT 3096-R

Tabletop

- 14 gauge type 304 stainless steel.
- Rolled edge on front.
- Ends turned down at 90°.
- Top is reinforced with welded-on hat channel.
- Uni-lok® gusset system (patent #5,165,349): gusset is recessed into hat channel underside tabletop, reducing lateral movement.
- Full-length 4½" (114mm)-high backsplash.
- 16" x 19" x 8" (406 x 483 x 127mm) recessed stainless steel sink bowl with deck mount faucet with 12" (305mm) swivel spout.
- 20" x 20" x 5" (508 x 508 x 127mm), stainless steel drawer assembly with pull flange.
- ½" (13mm) thick polymer cutting board is 18¼" x 20¼" (464 x 527mm), designed to fit inside recessed area of sink to double as a sink cover.

Adjustable Undershelf

- Heavy gauge stainless steel.
- Gusset welded to each corner.

Legs

- Heavy gauge stainless steel.
- 1½" (41mm)-diameter.
- Adjustable stainless steel feet.

EAGLE GROUP
 100 Industrial Boulevard, Clayton, DE 19938-8903 USA
 Phone: 302-653-3000 • Fax: 302-653-2065
 www.eaglegrp.com

Foodservice Division: Phone 800-441-8440
MHC/Retail Display Divisions: Phone 800-637-5100

For custom configuration or fabrication needs, contact our **SpecFAB® Division**.
 Phone: 302-653-3000 • Fax: 302-653-2065 • e-mail: quotes@eaglegrp.com



EG10.18 Rev. 01/15

Spec sheets available for viewing, printing or downloading from our online literature library at www.eaglegrp.com

Eagle Foodservice Equipment, Eagle MHC, SpecFAB®, and Retail Display are divisions of Eagle Group. ©2015 by the Eagle Group



Profit from the Eagle Advantage®

Item No.: _____
 Project No.: _____
 S.I.S. No.: _____

Spec-Master® Prep Tables

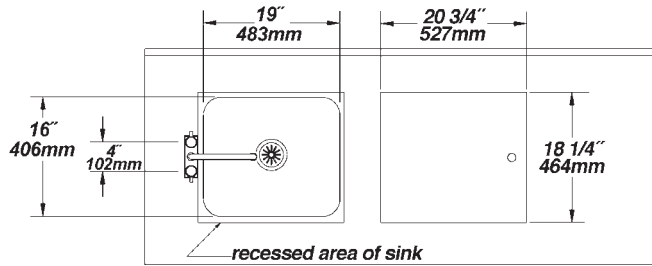

TOP VIEW

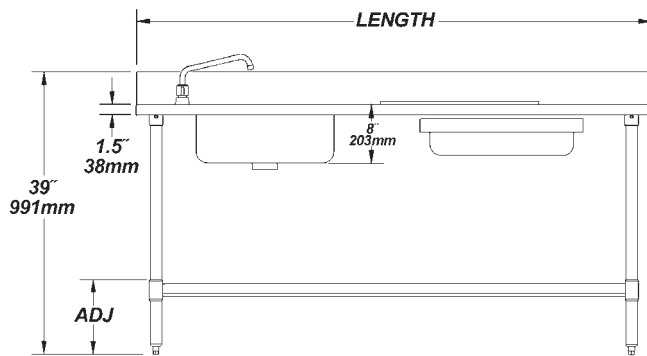

FRONT VIEW

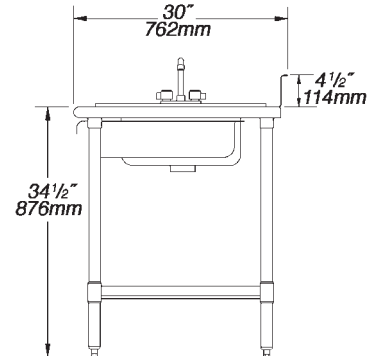

SIDE VIEW

with Left-End Sink, Right-End Drawer		with Right-End Sink, Left-End Drawer		width		length		weight	
model #	model #	in.	mm	in.	mm	lbs.	kg		
PT 3072	PT 3072-R	30"	762	72"	1829	150	68.0		
PT 3084	PT 3084-R	30"	762	84"	2134	175	79.4		
PT 3096	PT 3096-R	30"	762	96"	2438	212	96.2		

EAGLE GROUP
 100 Industrial Boulevard, Clayton, DE 19938-8903 USA
 Phone: 302-653-3000 • Fax: 302-653-2065
 www.eaglegrp.com

Foodservice Division: Phone 800-441-8440
 MHC/Retail Display Divisions: Phone 800-637-5100

Printed in U.S.A.
 ©2015 by Eagle Group

Rev. 01/15

Spec sheets available for viewing, printing or downloading from our online literature library at www.eaglegrp.com

Although every attempt has been made to ensure the accuracy of the information provided, we cannot be held responsible for typographical or printing errors. Information and specifications are subject to change without notice. Please confirm at time of order.