

Job: \_\_\_\_\_

Item: \_\_\_\_\_

Quantity: \_\_\_\_\_

## Cup/Glass Rack Dollies

These dollies are specifically designed to hold 20" x 20" or smaller cup and glass racks.

- The single dolly is constructed with a 1 1/4" x 1 1/4" x .070" wall tube.
- Casters plates are welded onto the framework to support the platform type casters.
- Double and Triple Dollies are constructed with a 1 1/2" x 1 3/4" x .070" wall tube. This adds support for a heavier load.
- All racks have a .080" sheet top with lips turned up to hold the trays in place.

### CASTERS:

- Equipped with four 5" platform type swivel casters.
- Double and Triple Dollies come with two 5" platform type swivel caster and two 5" platform type rigid casters.

### GUARANTEE:

- Lifetime Guarantee against rust and corrosion.
- Five-Year Guarantee against workmanship and material defects.

NSF Certified.



Model No.	# Of Stacks	Size W-H-D	Wt. Cap.	Ship Lbs.
1176A	Single	20 5/8" x 9 3/8" x 22 3/8"	1000 lbs.	21
1179A	Handle			3.5

**Single:** Four 5" platform type swivel casters (#C450).

**Double & Triple:** Four 5" platform type casters;  
 - two swivel (#C450), two rigid (#C460).

### OPTIONS:

**Corner Bumpers (4)** -- Add "B" suffix to model #.

**Caster Locks (2)** -- Add "CL" suffix to model #.



#1176A



#1179A

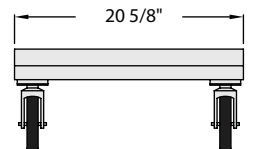
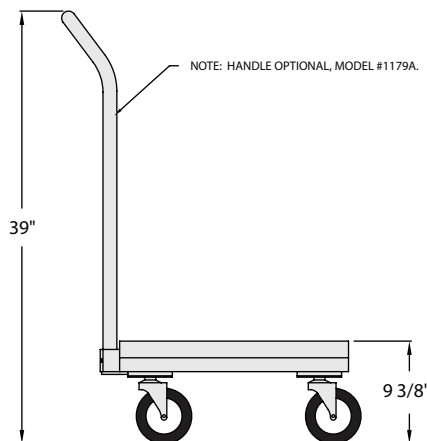
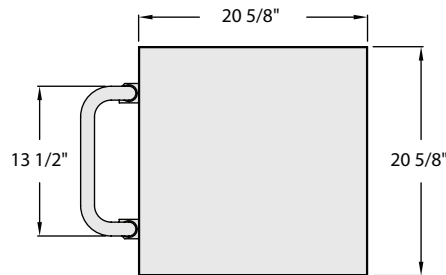

*This information is for general sales and engineering use only. New Age Industrial reserves the right to modify or make changes at any time without notice to materials and specifications.*

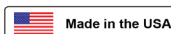

Distributed by: