

Job: \_\_\_\_\_

Item: \_\_\_\_\_

Quantity: \_\_\_\_\_

## Super Dolly

Built to handle heavy loads, these dollies make a quick and convenient aisle display as well as a heavy-duty mobile storage unit. Unique compact design minimizes wasted space and is easily maneuvered down narrow aisles.

- Framework is constructed out of 1 ½" x 1 ¾" x .700" wall tubing.
- Laterals are constructed of 1 ½" x 1 ½" x .070" wall tubing.

### CASTERS:

- **Model #1181** comes equipped with four 6" platform type casters, two swivel and two rigid.
- **Model #1182** comes equipped with four 5" platform type casters, two swivel and two rigid.

### GUARANTEE:

- Lifetime Guarantee against rust and corrosion.
- Five-Year Guarantee against workmanship and material defects.

NSF Certified.



Model No.	Size W-H-D	Wheel Size	Wt Cap.	Ship Lbs.
1181	24" x 10" x 29½"	6"	2800 lbs.	30
1182	24" x 8" x 29½"	5"	1000 lbs.	18

Four platform type casters - two swivel, two rigid.

#1181 = 2 swivel (#C490) 2 rigid (#C500)

#1182 = 2 swivel (#C450) 2 rigid (#C460)

### Options:

**Corner Bumpers (4)** -- Add "B" suffix to model #.

**Caster Locks (2)** -- Add "CL" suffix to model #.

### Aluminum Drag Hook

1199	37½" Long	1
------	-----------	---



1182



1199

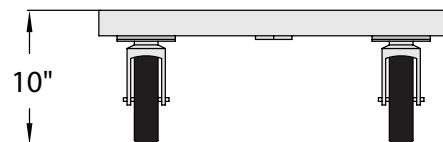
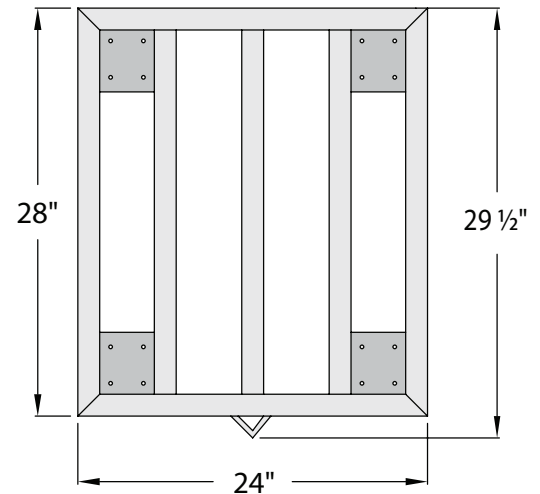

*This information is for general sales and engineering use only. New Age Industrial reserves the right to modify or make changes at any time without notice to materials and specifications.*

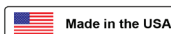

Distributed by: