



JOB:
ITEM:
QTY:



DOUGH DOLLIES

APPLICATION:

These dollies are specifically designed for dough trays and boxes. When these dollies are not in use that stack for easy storage.

MATERIAL:

Framework is constructed out of 1 1/2" x 1 1/2" x 3/16" wall angle. Caster bracket is constructed out of .063" sheet.

CASTERS:

Model #1195 comes equipped with four 3" platform type swivel casters. Model #1196 comes equipped with four 5" platform type swivel casters.

GUARANTEE:

These dollies carry a **Lifetime Guarantee** against rust and corrosion and also carry a **Five-Year Guarantee** against workmanship and material defects.



Model #1195



Phone: 800-255-0104
Fax: 877-877-7687
www.newageindustrial.com
sales@newageindustrial.com

New Age Industrial reserves the right to modify or make changes at any time without notice to materials and specifications.

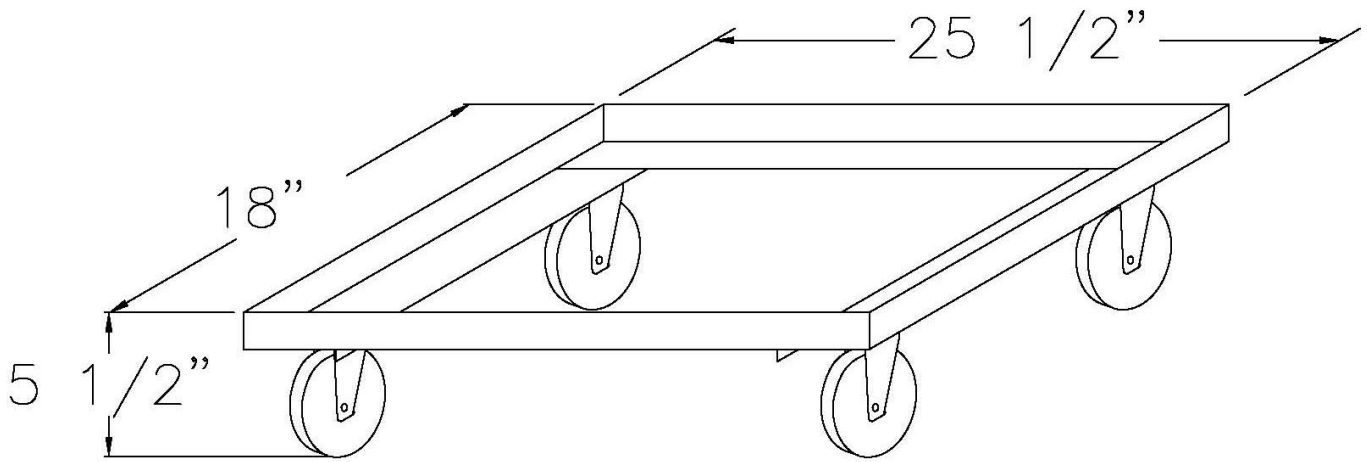

Model #1195

Model No.	Size-W	Size-H	Size-D	Wheel Size
1195	18"	5 1/2"	25 1/2"	3"
1196	18"	8"	25 1/2"	5"



Phone: 800-255-0104
 Fax: 877-877-7687
www.newageindustrial.com
sales@newageindustrial.com

New Age Industrial reserves the right to modify or make changes at any time without notice to materials and specifications.