



JOB:
ITEM:
QTY:



TUBULAR DECK CART

APPLICATION:

This double deck, tubular deck cart moves product at a convenient workable height from the floor. All-welded construction provides for heavy-duty stocking and produce operations. Perfect design for narrow aisles with a width of 19".

MATERIAL:

Framework is constructed out of 1 1/2"x 1 1/4"x.070" wall tubing. Uprights and handle are constructed out of 1 5/16" diameter pipe.

CASTERS:

This cart comes equipped with four 5" platform type casters, two swivel and two rigid.

GUARANTEE:

This cart carries a **Lifetime Guarantee** against rust and corrosion and also carries a **One-Year Guarantee** against workmanship and material defects.



Model #95661



Phone: 800-255-0104
Fax: 877-877-7687
www.newageindustrial.com
sales@newageindustrial.com

New Age Industrial reserves the right to modify or make changes at any time without notice to materials and specifications.

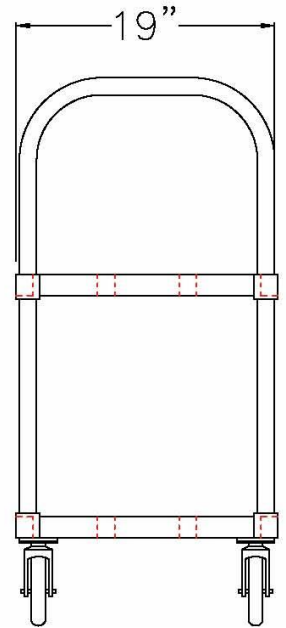
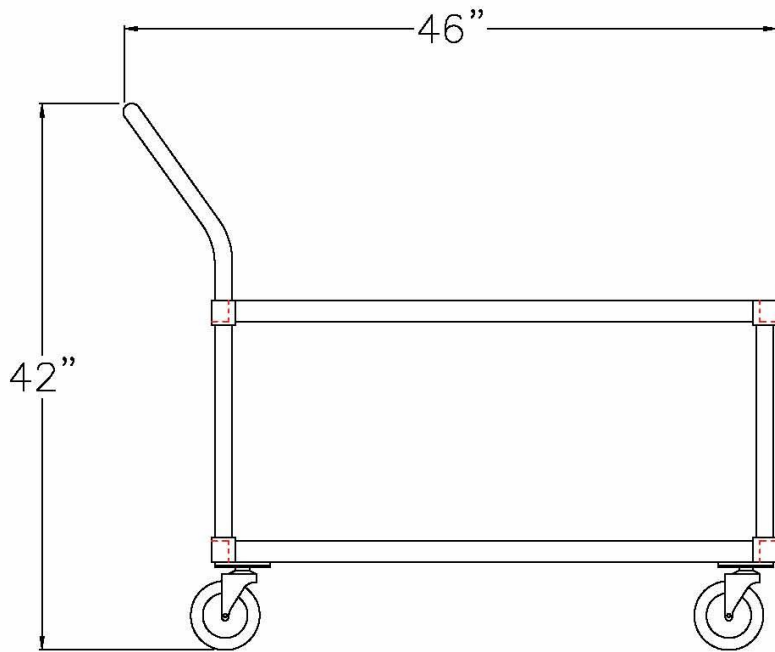

Model #95661

| Model No. | Size-W | Size-H | Size-D | Wt. Cap. |
|-----------|--------|--------|--------|----------|
| 95661 | 19" | 42" | 46" | 700# |



Phone: 800-255-0104
 Fax: 877-877-7687
www.newageindustrial.com
sales@newageindustrial.com

New Age Industrial reserves the right to modify or make changes at any time without notice to materials and specifications.