

NOR-LAKE, INCORPORATED
 727 Second Street
 P.O. Box 248
 Hudson, Wisconsin 54016

800-955-5253
 715-386-2323
 800-388-5253 Service
 866-961-5253 Parts
 715-386-4291 FAX
 www.norlake.com

NORLAKE®



VERTICAL OPEN AIR MERCHANDISERS



NLVOAM36-60

NLVOAM72-79

PROJECT:

ITEM NUMBER:

MODEL NUMBER:

SPECIFICATIONS FOR: NLVOAM36, NLVOAM48, NLVOAM60 & NLVOAM72

Available in: 60", 72" and 79" heights

- **Finish:** 24 gauge black painted textured galvanized steel interior and exterior front and top
- **Insulation:** 2" foamed-in-place "zero ODP" urethane insulation
- **Hardware:** Electronically controlled monitoring system, adjustable two-position shelves with price tag molding, LED lighting in canopy, stainless steel floor pans, automatic defrost, retractable vinyl night curtain
- **Electrical:** 115 volt, 60 Hz, 1 phase with cord
- **Refrigeration:** Self-contained forced air R-404a refrigerant. Temperature range: +34°F to +41°F. Designed to operate in a maximum +75° - 55% RH ambient. Condensate evaporator pan provided, piping to floor drain recommended.
- **Approvals:** UL, C-UL Safety, UL-Sanitation & Department of Energy (DOE) listed

STANDARD FEATURES

- 24 gauge black painted textured galvanized steel interior and exterior front and top
- Automatic defrost
- Adjustable shelf
- Electronically controlled monitoring system
- LED lighting in canopy
- Retractable vinyl night curtain
- Stainless steel floor pans
- Temperature range: +34°F to +41°F
- Approvals: UL, C-UL Safety, UL-Sanitation & Department of Energy (DOE) listed
- Warranties: 3 year parts and labor, 5 year compressor

OPTIONAL FEATURES*

- Casters
- Condensate pump
- LED shelf light kit
- Product hooks
- Remote refrigeration system
- Security cover
- Stainless steel interior and exterior

*Most options are available one week from receipt of order. Please contact us for specific questions.

**C-UL is Underwriters Laboratories Safety Certification Mark which indicates that UL has tested the equipment to applicable CSA Standards.

**UL Sanitation is Underwriters Laboratories Sanitation Mark which indicates that UL has tested the equipment to applicable NSF Standards.

VERTICAL OPEN AIR MERCHANDISERS

60" HEIGHT MODEL SPECIFICATIONS

Models	NLVOAM36-60	NLVOAM48-60	NLVOAM60-60	NLVOAM72-60
Crated Weight (lbs) (kg)	520 (236)	630 (286)	740 (336)	850 (386)
Crated Height (in) (cm)	66 (168)	66 (168)	66 (168)	66 (168)
Crated Width (in) (cm)	45 (115)	60 (153)	69 (176)	81 (206)
Crated Depth (in) (cm)	40 (102)	40 (102)	40 (102)	40 (102)
Interior Height (in) (cm)	33-1/2 (85)	33-1/2 (85)	33-1/2 (85)	33-1/2 (85)
Interior Width (in) (cm)	33 (83-4/5)	45 (114-1/3)	57 (144-4/5)	69 (175-1/3)
Interior Depth (in) (cm)	23 (58-1/3)	23 (58-1/3)	23 (58-1/3)	23 (58-1/3)
Overall Height (in) (cm)	60 (150)	60 (150)	60 (150)	60 (150)
Overall Width (in) (cm)	35-1/2 (88-3/4)	47-1/2 (118-3/4)	59-1/2 (148-3/4)	71-1/2 (178-3/4)
Overall Depth (in) (cm)	34 (85)	34 (85)	34 (85)	34 (85)
Gross Cubage (CuFt) (L)	13.4 (379.2)	18.2 (515.1)	23.1 (653.7)	28.0 (792.4)
Number of Shelves	2	2	4	4
Shelf Area (SqFt) (Sqm)	8.2 (0.76)	11.2 (1.04)	14 (1.32)	17.2 (1.6)
Condensing Unit Size	1/2 HP	3/4 HP	1 HP	1 HP
Refrigerant	R-404a	R-404a	R-404a	R-404a
Electrical Characteristics	115/60/1	115/60/1	115/60/1	115/60/1
Cord and Plug Furnished	Yes	Yes	Yes	Yes
NEMA Plug Configuration	5-15P	5-20P	5-20P	5-20P
Total Amp Draw **	8.0	11.5	14.5	14.5

** Factory installed condensate evaporator pan requires a dedicated 15 amp, 120 volt circuit.

Note: 208-230/60/1 also requires neutral and safety ground wire.

Specifications subject to change without notice.

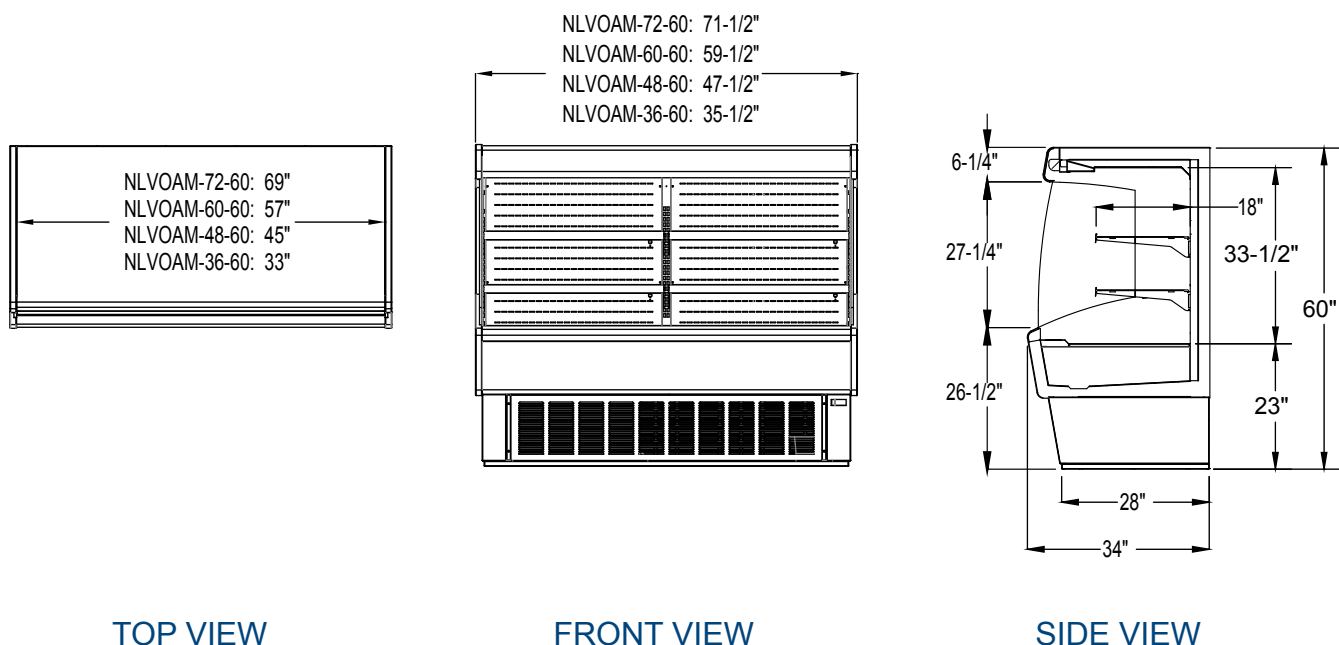

TOP VIEW

FRONT VIEW

SIDE VIEW

72" HEIGHT MODEL SPECIFICATIONS

Models	NLVOAM36-72	NLVOAM48-72	NLVOAM60-72	NLVOAM72-72
Crated Weight (lbs) (kg)	540 (245)	665 (302)	790 (359)	910 (414)
Crated Height (in) (cm)	78 (199)	78 (199)	78 (199)	78 (199)
Crated Width (in) (cm)	45 (115)	60 (153)	69 (176)	81 (206)
Crated Depth (in) (cm)	40 (102)	40 (102)	40 (102)	40 (102)
Interior Height (in) (cm)	45-1/2 (115-2/3)	45-1/2 (115-2/3)	45-1/2 (115-2/3)	45-1/2 (115-2/3)
Interior Width (in) (cm)	33 (83-4/5)	45 (114-1/3)	57 (144-4/5)	69 (175-1/3)
Interior Depth (in) (cm)	23 (58-1/3)	23 (58-1/3)	23 (58-1/3)	23 (58-1/3)
Overall Height (in) (cm)	72 (180)	72 (180)	72 (180)	72 (180)
Overall Width (in) (cm)	35-1/2 (88-3/4)	47-1/2 (118-3/4)	59-1/2 (148-3/4)	71-1/2 (178-3/4)
Overall Depth (in) (cm)	34 (85)	34 (85)	34 (85)	34 (85)
Gross Cubage (CuFt) (L)	17.8 (503.7)	24.2 (684.9)	30.7 (868.8)	37.1 (1049.9)
Number of Shelves	3	3	6	6
Shelf Area (SqFt) (Sqm)	12.3 (1.14)	16.8 (1.56)	21 (1.98)	25.8 (2.4)
Condensing Unit Size	3/4 HP	1 HP	1 HP	1 HP
Refrigerant	R-404a	R-404a	R-404a	R-404a
Electrical Characteristics	115/60/1	115/60/1	208-230/60/1	208-230/60/1
Cord and Plug Furnished	Yes	Yes	Yes	Yes
NEMA Plug Configuration	5-20P	5-20P	L14-20P	L14-20P
Total Amp Draw **	11.5	14.5	7.8	7.8

** Factory installed condensate evaporator pan requires a dedicated 15 amp, 120 volt circuit.

Note: 208-230/60/1 also requires neutral and safety ground wire.

Specifications subject to change without notice.

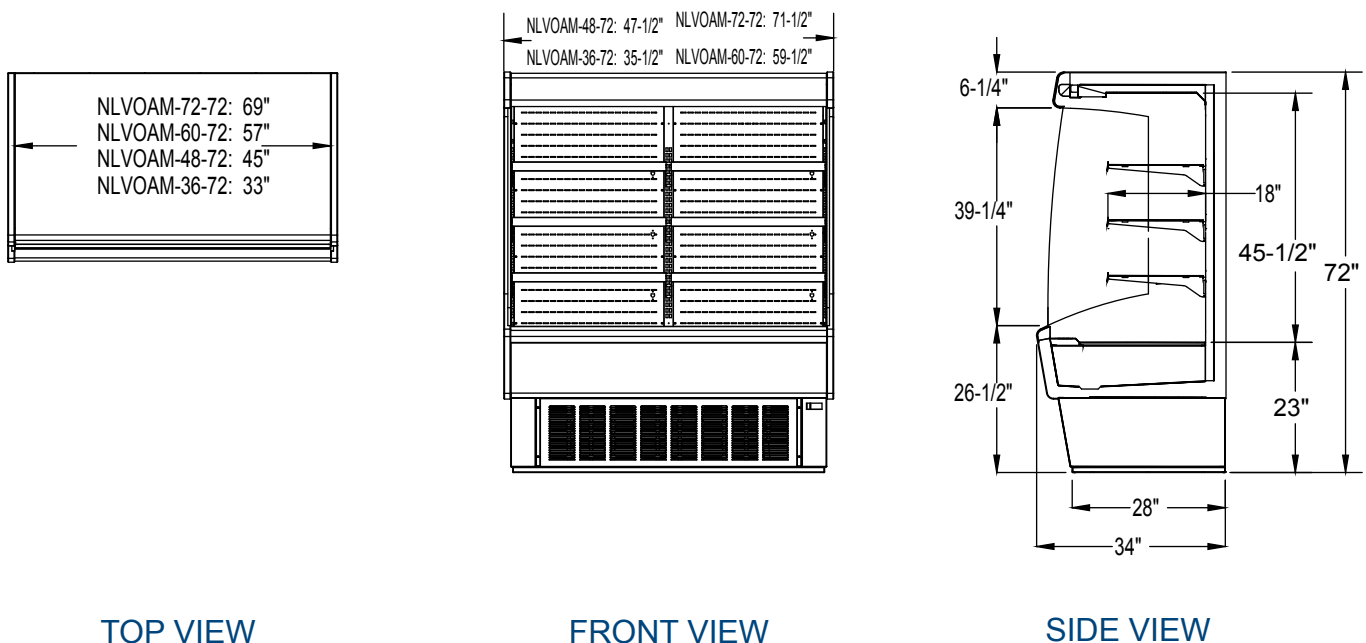

TOP VIEW

FRONT VIEW

SIDE VIEW

79" HEIGHT MODEL SPECIFICATIONS

Models	NLVOAM36-79	NLVOAM48-79	NLVOAM60-79	NLVOAM72-79
Crated Weight (lbs) (kg)	550 (250)	675 (307)	800 (364)	925 (420)
Crated Height (in) (cm)	85 (216)	85 (216)	85 (216)	85 (216)
Crated Width (in) (cm)	45 (115)	60 (153)	69 (176)	81 (206)
Crated Depth (in) (cm)	40 (102)	40 (102)	40 (102)	40 (102)
Interior Height (in) (cm)	52-1/2 (133-1/3)	52-1/2 (133-1/3)	52-1/2 (133-1/3)	52-1/2 (133-1/3)
Interior Width (in) (cm)	33 (83-4/5)	45 (114-1/3)	57 (144-4/5)	69 (175-1/3)
Interior Depth (in) (cm)	23 (58-1/3)	23 (58-1/3)	23 (58-1/3)	23 (58-1/3)
Overall Height (in) (cm)	79 (197-1/2)	79 (197-1/2)	79 (197-1/2)	79 (197-1/2)
Overall Width (in) (cm)	35-1/2 (88-3/4)	47-1/2 (118-3/4)	59-1/2 (148-3/4)	71-1/2 (178-3/4)
Overall Depth (in) (cm)	34 (85)	34 (85)	34 (85)	34 (85)
Gross Cubage (CuFt) (L)	20.8 (588.6)	28.3 (800.9)	35.9 (1015.9)	43.4 (1228.2)
Number of Shelves	4	4	8	8
Shelf Area (SqFt) (Sqm)	16.4 (1.52)	22.4 (2.08)	28 (2.64)	34.4 (3.2)
Condensing Unit Size	3/4 HP	1 HP	1 HP	1 HP
Refrigerant	R-404a	R-404a	R-404a	R-404a
Electrical Characteristics	115/60/1	115/60/1	208-230/60/1	208-230/60/1
Cord and Plug Furnished	Yes	Yes	Yes	Yes
NEMA Plug Configuration	5-20P	5-20P	L14-20P	L14-20P
Total Amp Draw **	11.5	14.5	7.8	7.8

** Factory installed condensate evaporator pan requires a dedicated 15 amp, 120 volt circuit.

Note: 208-230/60/1 also requires neutral and safety ground wire.

Specifications subject to change without notice.

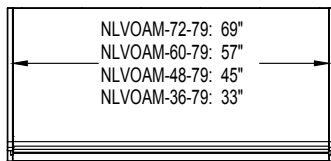

TOP VIEW

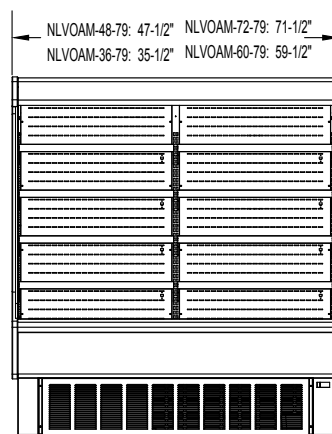

FRONT VIEW

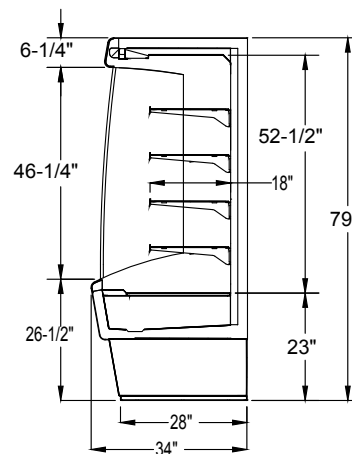

SIDE VIEW



NORLAKE[®]

Revision Date: 08/15
 © 2015 NOR-LAKE, INC.
 Printed in the U.S.A.
 Part Number: 157802

