

ALPA-120[®]



a COOL business



Maintenance Free Condenser

The finless spiral condenser design prevents dust/dirt buildup allowing maximum long term efficiency.



Steel Construction

Robust steel construction minimizes the use of plastic materials resulting in an environmental friendly design.



Electronic Temperature Control

The intelligent temperature control is programmed to ensure the correct operation of the equipment and maintain products at an optimum temperature.



LED lighting

LED lighting lasts longer than fluorescent lighting, it reduces energy consumption and generates minimal heat. All of this make LED lighting great for the environment.



Night Curtain

30% less energy consumption when closed.



Hot Gas Evaporation

Hot gas heated drain pan for condensate evaporation that eliminates the need of floor drains or electric heaters.



Custom Graphics

Standard color: grey. Optional: blue, red, white, or custom graphics.

CABINET CONSTRUCTION

- High-density, CFC-Free, polyurethane insulation
- Large low-E double pane tempered thermal glass side panels
- Manual, retractable night curtain for increased energy savings
- Exterior: Galvanized metal cabinet with powder coated painted surface
- Interior: Easy to clean pre painted steel

REFRIGERATION

- Maintenance free condensers
- Automatic self defrost cycle
- Hot gas heated drain pan for condensate evaporation
- Electronic temperature control
- Easy to reach components for repairs

LIGHTING

- LED horizontal and vertical lighting

OPERATING CONDITIONS

- Open Air models should not be installed in any area where the air curtain will be frequently disrupted. This includes placement near any HVAC vent, open doorway, or fan
- The unit is best suited for an environment where temperatures remain below 75 F and humidity does not exceed 55%
- Areas with direct sunlight should also be avoided

SHELVING

- Adjustable shelves/dual position with tag molding

OPTIONS

- 6" stainless steel legs
- Castors
- Lockable Security Cage
- Clear cool Curtain
- Peg Bar system for hanging product
- Shelf Product Retainers
- Custom graphics
- Saddle Bag merchandisers
- Front Product merchandiser

NEMA

- Required NEMA configuration: 5-15R

WARRANTY

- 1 year parts and labor
- 5 year compressor

Dimensions			Shelves	HP	Voltage	Amps	Crated Weigth
L	D	H					
51.88 in 1317 mm	30.25 in 768 mm	77 in 1955 mm	5	2 x 1/3+	120	16	634 lbs
Crated Dimensions			Net Capacity, cf: 24.2		Energy Consumption: 17.28 kw-hr /day		
56.29 in 1430 mm	36.22 in 920 mm	82.67 in 2100 mm					

Branding Dimensions

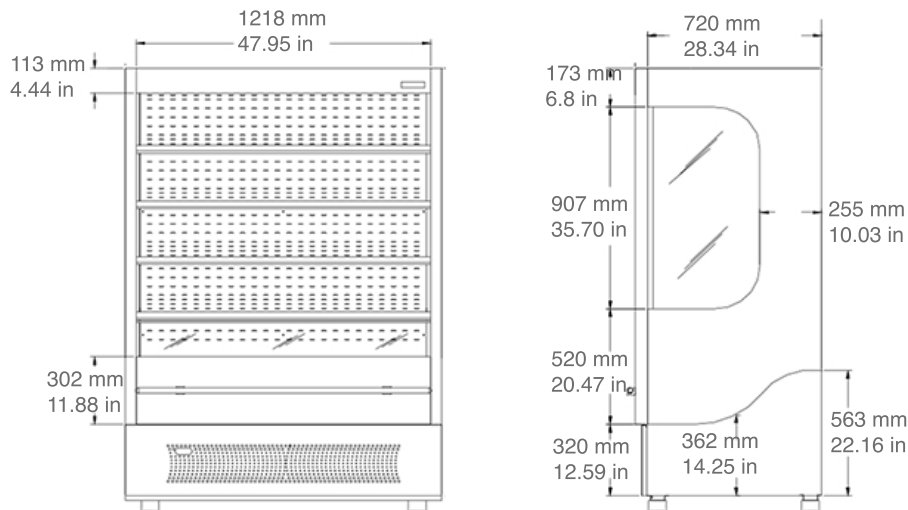

Consumption Equivalent to 7.2 light bulbs of 100 watts

