

# 8- Flavor Dip



a COOL business



## Adjustable Thermostat

Freezers are equipped with a mechanical thermostat that allows the users to adjust the temperature that best fits their products needs. Set from factory at -0.4°F.



## High Impact ABS Frame

Made of a high impact durable plastic, this frame assures a long-term life span.



## Heavy Duty Casters

Equiped with durable casters that allow easy and fast movement in the store.



## Steel Construction

Robust steel construction minimizes the use of plastic materials resulting in an environmental friendly design.



## Custom Graphics

Standard: with graphics (see image). Optional: various cabinet colors or custom graphics.



## CABINET CONSTRUCTION

- High-density, CFC-Free, polyurethane insulation
- Low-E tempered sliding glass lids with lock and keys
- High Impact ABS top Frame
- Exterior: Galvanized metal cabinet with powder coated painted surface
- Interior: Easy to clean pre-painted steel
- Heavy Duty Castors
- Drain plug for easy cleaning
- Lexan Sneeze Guard
- Holds 8-3 Gallon Tubs
- Stores 6-3 Gallon Tubs in bottom

## REFRIGERATION

- Maintenance free condenser

- Adjustable Thermostat
- Easy to reach components for repairs
- Triple access air flow compressor compartment

## OPERATING CONDITIONS

- The unit is best suited for an environment where temperatures remain below 85°F and humidity does not exceed 55%
- Areas with direct sunlight should also be avoided

## OPTIONS

- Custom graphics
- LED lighting
- Dip Well

## WARRANTY

- 2 years parts and labor
- 5 years compressor part

## NEMA

- Required NEMA configuration: 5-15R

Dimensions			Baskets	HP	Voltage	Amps	Crated Weight
L	D	H					
50.6 in 1285 mm	26.2 in 665 mm	51 in 1295 mm	N/A	1/3+	120	5.2	240 lbs
				Net Capacity, cf: 10.3 (291 L)		Energy Consumption: 3.52 kw-hr /day	

## Branding Dimensions

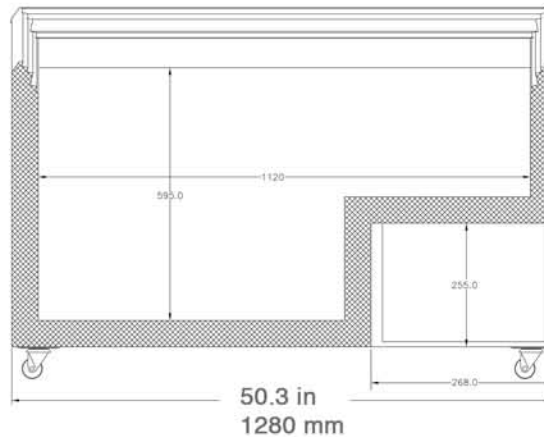
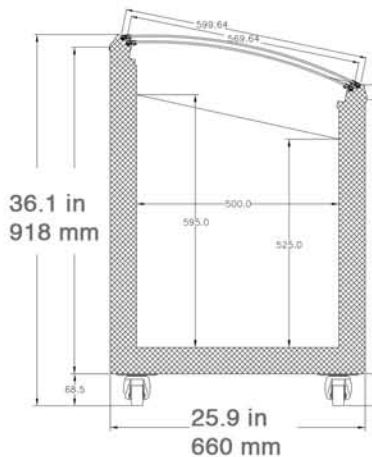

Consumption Equivalent to  
2.6 light bulbs of 50 watts

