



REFRIGERATION

SERVING THE FOOD INDUSTRY SINCE 1951

17-INCH COUNTERTOP FOUR SIDED GLASS REFRIGERATED SHOWCASE

Item: 25826 Model: RS-CN-0078-S | Item: 25827 Model: RS-CN-0078-D



Ideal for restaurants, cafes, and/or bakeries, Omcan's 17-inch countertop four sided glass refrigerated displays are perfect for your customers to easily see which products are for sale. Featuring their crystal clear glass design, these refrigerated showcases have internal LED lighting, as well as digital temperature controls. It also has adjustable shelf positions.

Product may not be exactly as shown.



WARRANTY
PARTS AND LABOR



SHIPPED ON PALLET



NEMA
5 - 15
125 VAC / 15 AMP



Authorized Dealer

REFRIGERATION

17-INCH COUNTERTOP FOUR SIDED GLASS REFRIGERATED DISPLAY
SINGLE DOOR



TECHNICAL SPECIFICATION

| | |
|-------------------------|--|
| ITEM NUMBER | 25826 |
| MODEL | RS-CN-0078-S |
| DESCRIPTION | Single Door |
| POWER | 0.164 kW |
| ELECTRICAL | 110V/60Hz/1Ph |
| LAMP POWER (W) | 1.44*4(LED) |
| TEMPERATURE RANGE | 0 - 12°C / 32 - 54°F |
| REFRIGERANT & INJECTION | R134a (83g) |
| TYPE OF CLIMATE | N |
| RATED CURRENT (A) | 2.4 |
| CAPACITY (L/ CU. FT.) | 82 L / 2.90 cu. ft. |
| NUMBER OF SHELVES | 3 |
| WEIGHT | 79 lbs. / 36 kg. |
| PACKAGING WEIGHT | 85 lbs. / 39 kg. |
| DIMENSIONS (DWH) | 16" x 16.75" x 38.5" 406 x 425 x 978 mm |
| PACKAGING DIMENSIONS | 19" x 18" x 41" 483 x 457 x 1041 mm |



TECHNICAL DRAWING AND DIMENSIONS

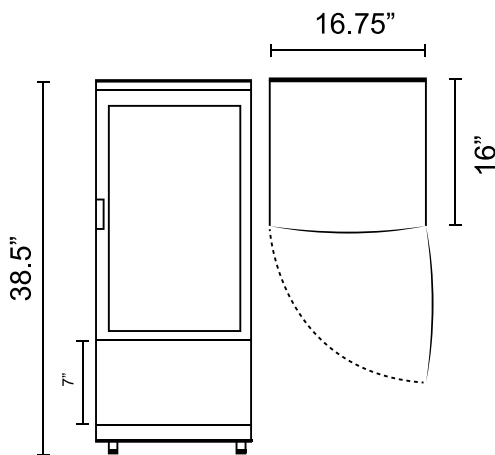

Features:

- Internal LED lighting
- Temperature controls
- Adjustable shelf positions
- Single door
- Capacity: 82 L / 2.90 cu. ft.
- Temperature range: 0 - 12°C / 32 - 54°F



WARRANTY
PARTS AND LABOR

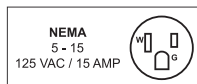

OMCAN INC.

Telephone: 1-800-465-0234

Fax: (905) 607-0234

Email: sales@omcan.com

Website: www.omcan.com



Follow us to keep up to date with the latest news and offers



2015.E.O.E

REFRIGERATION

17-INCH COUNTERTOP FOUR SIDED GLASS REFRIGERATED DISPLAY
DUAL DOOR



TECHNICAL SPECIFICATION

| | |
|-------------------------|---|
| ITEM NUMBER | 25827 |
| MODEL | RS-CN-0078-D |
| DESCRIPTION | Two Door |
| POWER | 0.164 kW |
| ELECTRICAL | 110V/60Hz/1Ph |
| LAMP POWER (W) | 1.44*4(LED) |
| TEMPERATURE RANGE | 0 - 12°C / 32 - 54°F |
| REFRIGERANT & INJECTION | R134a (83g) |
| TYPE OF CLIMATE | N |
| RATED CURRENT (A) | 2.4 |
| CAPACITY (L/ CU. FT.) | 86 L / 3 cu. ft. |
| NUMBER OF SHELVES | 3 |
| WEIGHT | 80 lbs. / 36 kg. |
| PACKAGING WEIGHT | 86 lbs. / 39 kg. |
| DIMENSIONS (DWH) | 16.75" x 16.75" x 38.5" 425 x 425 x 978 mm |
| PACKAGING DIMENSIONS | 19" x 19" x 41" 482 x 482 x 1041 mm |



TECHNICAL DRAWING AND DIMENSIONS

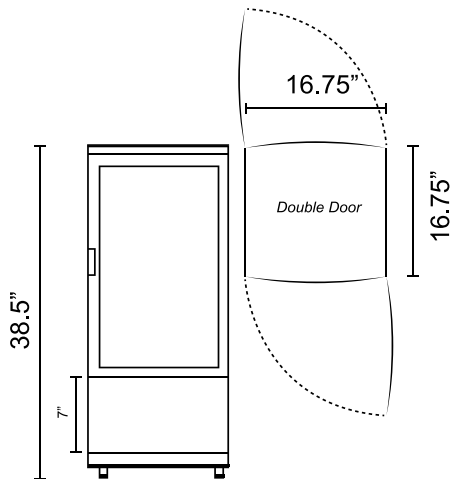

Features:

- Internal LED lighting
- Temperature controls
- Adjustable shelf positions
- Two door
- Capacity: 86 L / 3 cu. ft.
- Temperature range: 0 - 12°C / 32 - 54°F



WARRANTY
PARTS AND LABOR

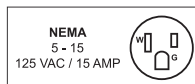

OMCAN INC.

Telephone: 1-800-465-0234

Fax: (905) 607-0234

Email: sales@omcan.com

Website: www.omcan.com



Follow us to keep up to date with the latest news and offers



2015.E.O.E