



REFRIGERATION

CENTER OF ALL YOUR FOOD SERVICE NEEDS

Open Refrigerated Floor Display Case with 8.12 Cu.Ft.

Item #: 40438

Model: RS-CN-0230



*High Performance
and Quality
Open Refrigerated
Floor Display Case*

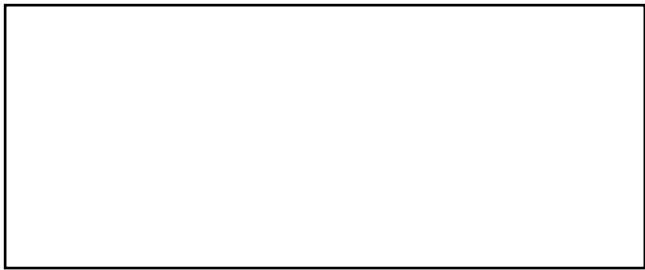

Authorized Dealer

REFRIGERATION

OPEN REFRIGERATED FLOOR DISPLAY CASE



Great for displaying dairy products, vegetables, fruits and drinks.

Features:

- ① Pull down curtain.
- ② LED lighting.
- ③ Adjustable shelf position.
- ④ Digital temperature controls.
- ⑤ Casters.

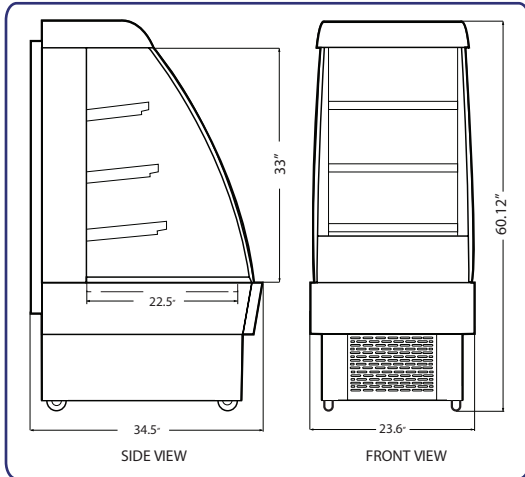

NEMA
5 - 15
125 VAC / 15 AMP



PRODUCT SPECIFICATIONS

ITEM NUMBER	40438	TYPE OF CLIMATE	6
MODEL	RS-CN-0230	RATED CURRENT (A)	10.1
RATED INPUT POWER	1045 W	SHELF SIZE (DxW)	10" / 12" / 14" x 19.50"
ELECTRICAL HEATING ELEMENT	450 W	INNER DIMENSIONS (WDH)	21.35" x 22.5" x 33"
CAPACITY (L / CU. FT.)	230 L / 8.12 cu.ft.	FOAMING AGENT	XPS
ELECTRICAL	110 V / 60 Hz / 1	WEIGHT	92 kg. / 202.4 lbs.
LAMP POWER (W)	1.44 Watts x 2 (LED)	PACKAGING WEIGHT	102 kg. / 224.4 lbs.
TEMPERATURE	2 - 10°C / 35.6 - 50°F	DIMENSIONS (WDH)	23.6" x 34.50" x 60.12"
AMBIENT TEMPERATURE./RH	<27°C (80.6°F) / 70%	PACKAGING DIMENSIONS	26" x 38" x 63"
REFRIGERANT & INJECTION	R134a and 380		

OMCAN INC.

Telephone: 1-800-465-0234
 Fax: (905) 607-0234
 E-mail: sales@omcan.com
 Website: www.omcan.com



Follow us to keep up to date with the latest news and offers

