



COOKING EQUIPMENT

SERVING THE FOOD INDUSTRY SINCE 1951

COUNTERTOP STAINLESS STEEL GAS GRIDDLE WITH THERMOSTATIC CONTROL

Item: 43016
Model: CE-CN-G15TPF

Item: 43017
Model: CE-CN-G24TPF

Item: 43018
Model: CE-CN-G36TPF

Item: 43019
Model: CE-CN-G48TPF

OMCAN GAS EQUIPMENT SERIES

answers the needs of modern, busy catering establishments for reliable, well-built equipment that offers flexibility, performance, style and value for money. Omcan gas equipment has been designed with safety, ease of operation and performance as paramount. Omcan has a stylish and robust modular design, constructed of high quality brushed stainless steel, large "cool to touch" dials, large heavy-duty adjustable feet and easy to clean and remove accessories.

The Omcan Griddles feature polished steel cooking surface for the best results in grilling. Breakfast, lunch or dinner, these griddles offers flexibility for your menu needs.



Authorized Dealer



LIMITED WARRANTY
PARTS AND LABOR



COOKING EQUIPMENT

COUNTERTOP STAINLESS STEEL GAS GRIDDLE WITH THERMOSTATIC CONTROL



COUNTERTOP STAINLESS STEEL GAS GRIDDLES WITH THERMOSTATIC CONTROL

With 1 Burner



- Stainless steel construction and finish
- 3/4" thick polished steel and cooking surface
- Thermostatically controlled independent cooking zones
- Large and robust dial controls
- Stainless steel burners
- Burner thermostatic valves
- Removable full width waste tray
- Heavy-duty adjustable feet
- 3/4" rear gas connection
- Propane Conversion kit (43305) included

TECHNICAL SPECIFICATION

ITEM NUMBER	43016
MODEL	CE-CN-G15TPF
NUMBER OF BURNERS	1 Burner
B.T.U.	30,000
COOKING AREA (WD)	15" x 20" / 380 x 510 mm
*GAS TYPE	Natural Gas
TEMPERATURE	Thermostat Control
DIMENSION (WDH)	15" x 32.7" x 16.7" / 380 x 830 x 425 mm
PACKAGING DIMENSIONS (WDH)	17" x 32" x 18.5" / 430 x 820 x 470 mm
WEIGHT	111.6 lbs/ 50.60 kg
PACKAGING WEIGHT	136.1 lbs/ 61.75 kg

TECHNICAL DRAWING & DIMENSIONS

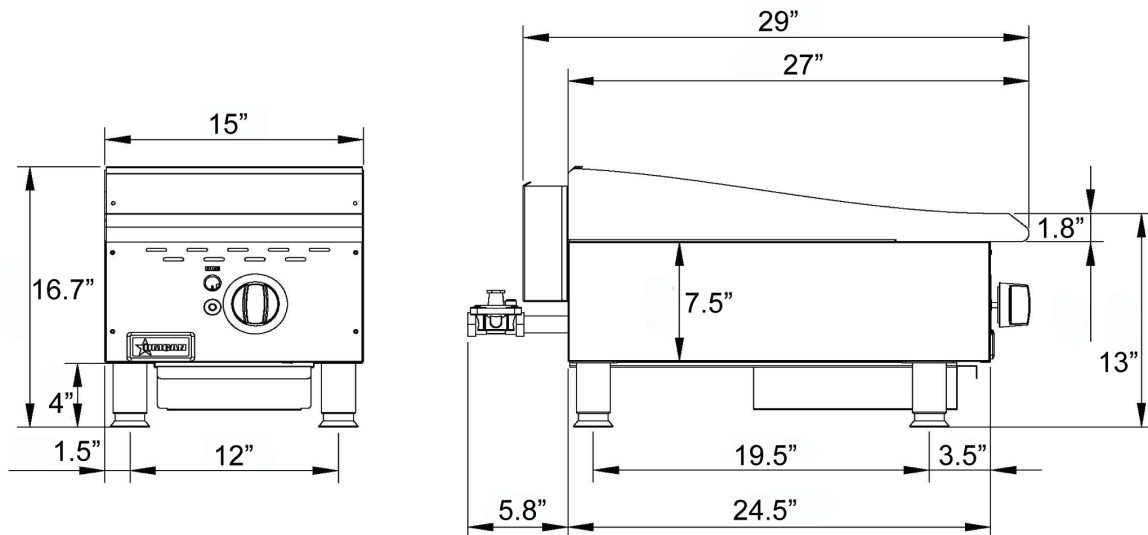

Gas conversion to be completed by an approved gas field technician

OMCAN INC.

Telephone: 1-800-465-0234
 Fax: (905) 607-0234
 Email: sales@omcan.com
 Website: www.omcan.com



Follow us to keep up to date with the latest news and offers



2015.E.O.E

COOKING EQUIPMENT

COUNTERTOP STAINLESS STEEL GAS GRIDDLE WITH THERMOSTATIC CONTROL



COUNTERTOP STAINLESS STEEL GAS GRIDDLES WITH THERMOSTATIC CONTROL

With 2 Burners



- Stainless steel construction and finish
- 3/4" thick polished steel and cooking surface
- Thermostatically controlled independent cooking zones
- Large and robust dial controls
- Stainless steel burners
- Burner thermostatic valves
- Removable full width waste tray
- Heavy-duty adjustable feet
- 3/4" rear gas connection
- Propane Conversion kit (43306) included

TECHNICAL SPECIFICATION

ITEM NUMBER	43017
MODEL	CE-CN-G24TPF
NUMBER OF BURNERS	2 Burners
B.T.U.	60,000
COOKING AREA (WD)	24" x 20" / 610 x 510 mm
*GAS TYPE	Natural Gas
TEMPERATURE	Thermostat Control
DIMENSION (WDH)	24" x 32.7" x 16.7" / 610 x 830 x 425 mm
PACKAGING DIMENSIONS (WDH)	26" x 32" x 18.5" / 660 x 820 x 470 mm
WEIGHT	125 lbs/ 56.85 kg
PACKAGING WEIGHT	164.5 lbs/ 74.6 kg

TECHNICAL DRAWING & DIMENSIONS

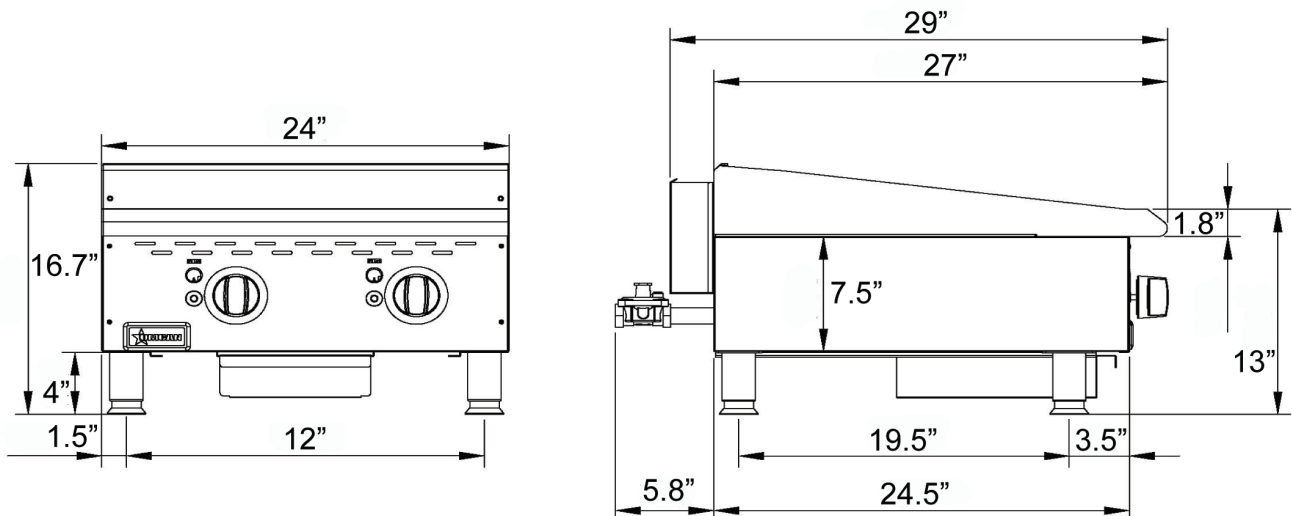

Gas conversion to be completed by an approved gas field technician

OMCAN INC.

Telephone: 1-800-465-0234
 Fax: (905) 607-0234
 Email: sales@omcan.com
 Website: www.omcan.com



Follow us to keep up to date with the latest news and offers



COOKING EQUIPMENT

COUNTERTOP STAINLESS STEEL GAS GRIDDLE WITH THERMOSTATIC CONTROL



COUNTERTOP STAINLESS STEEL GAS GRIDDLES WITH THERMOSTATIC CONTROL

With 3 Burners



- Stainless steel construction and finish
- 3/4" thick polished steel and cooking surface
- Thermostatically controlled independent cooking zones
- Large and robust dial controls
- Stainless steel burners
- Burner thermostatic valves
- Removable full width waste tray
- Heavy-duty adjustable feet
- 3/4" rear gas connection
- Propane Conversion kit (43307) included

TECHNICAL SPECIFICATION

ITEM NUMBER	43018
MODEL	CE-CN-G36TPF
NUMBER OF BURNERS	3 Burners
B.T.U.	90,000
COOKING AREA (WD)	36" x 20" / 915 x 510 mm
*GAS TYPE	Natural Gas
TEMPERATURE	Thermostat Control
DIMENSION (WDH)	36" x 32.7" x 16.7" / 915 x 830 x 425 mm
PACKAGING DIMENSIONS (WDH)	38" x 32" x 18.5" / 965 x 820 x 470 mm
WEIGHT	228 lbs/ 103.50 kg
PACKAGING WEIGHT	275 lbs/ 124.70 kg

TECHNICAL DRAWING & DIMENSIONS

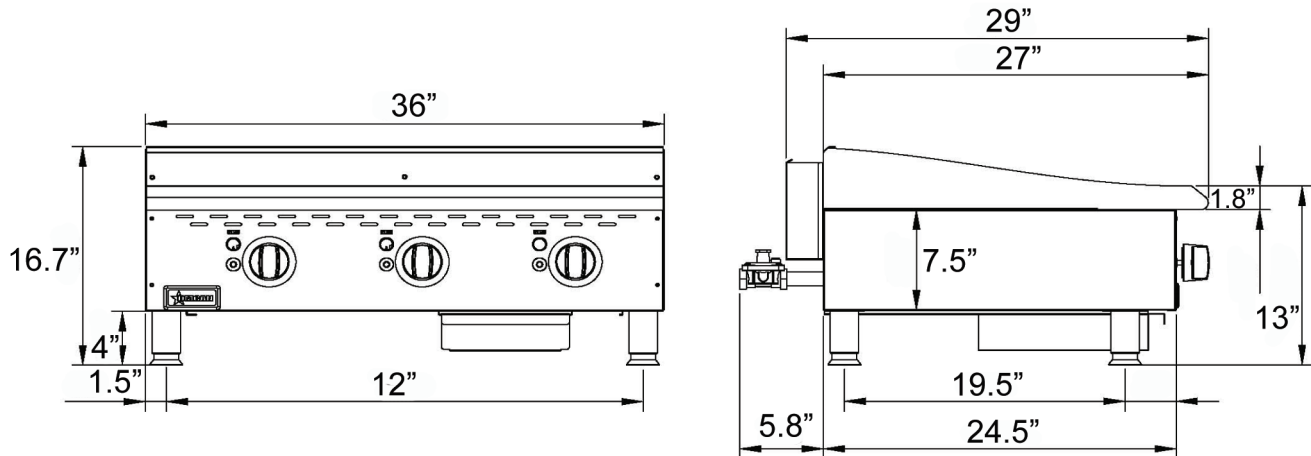

Gas conversion to be completed by an approved gas field technician

OMCAN INC.

Telephone: 1-800-465-0234
 Fax: (905) 607-0234
 Email: sales@omcan.com
 Website: www.omcan.com



Follow us to keep up to date with the latest news and offers



COOKING EQUIPMENT

COUNTERTOP STAINLESS STEEL GAS GRIDDLE WITH THERMOSTATIC CONTROL



COUNTERTOP STAINLESS STEEL GAS GRIDDLES WITH THERMOSTATIC CONTROL

With 4 Burners



- Stainless steel construction and finish
- 3/4" thick polished steel and cooking surface
- Thermostatically controlled independent cooking zones
- Large and robust dial controls
- Stainless steel burners
- Burner thermostatic valves
- Removable full width waste tray
- Heavy-duty adjustable feet
- 3/4" rear gas connection
- Propane Conversion kit (43308) included

TECHNICAL SPECIFICATION

ITEM NUMBER	43019
MODEL	CE-CN-G48TPF
NUMBER OF BURNERS	4 Burners
B.T.U.	120,000
COOKING AREA (WD)	48" x 20" / 1220 x 510 mm
*GAS TYPE	Natural Gas
TEMPERATURE	Thermostat Control
DIMENSION (WDH)	48" x 32.7" x 16.7" / 1220 x 830 x 425 mm
PACKAGING DIMENSIONS (WDH)	50" x 32" x 18.5" / 1270 x 820 x 470 mm
WEIGHT	300 lbs/ 136 kg
PACKAGING WEIGHT	360 lbs/ 163.15 kg

TECHNICAL DRAWING & DIMENSIONS

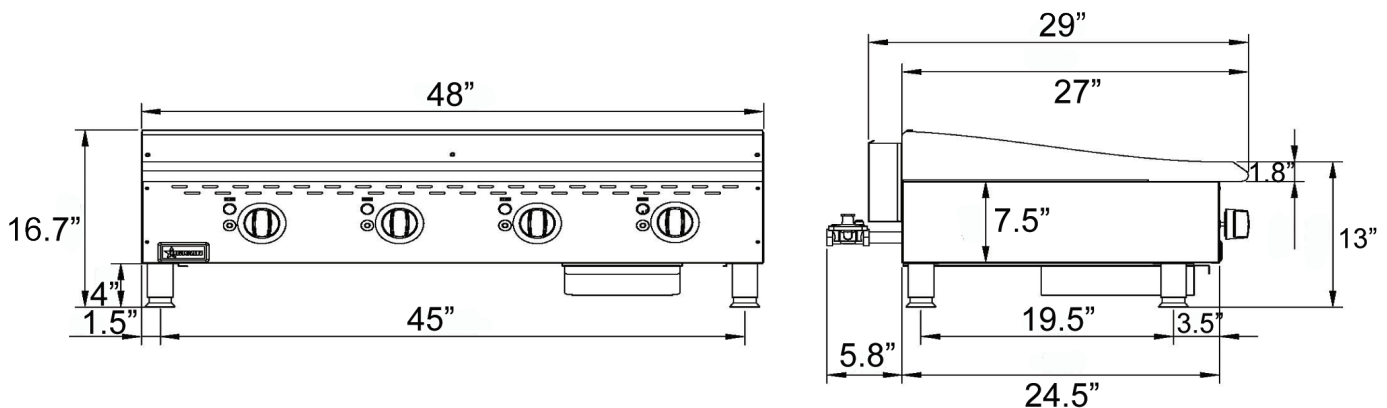

Gas conversion to be completed by an approved gas field technician

OMCAN INC.

Telephone: 1-800-465-0234
 Fax: (905) 607-0234
 Email: sales@omcan.com
 Website: www.omcan.com



Follow us to keep up to date with the latest news and offers

