

# The Shuttle<sup>®</sup> Oven

The speed and throughput of the Conveyor.  
The flexibility of our award-winning Matchbox.<sup>®</sup>



*Meets service times of conveyors during peak periods.  
Dramatically reduces service times in off-peak hours while enabling  
broad menu flexibility.*

## Two Modes of Operation:

### Shuttle Mode Enables Superior Cooking Control and Broad Menu Flexibility

- Revolutionary Precision Impingement<sup>®</sup> allows you to control time and independent blower speeds for every item
- Food automatically loads quickly – at the tap of a touchpad – reducing service times
- Stores cook settings for up to 1,000 menu items on an intuitive One-Touch display

### Conveyor Mode at the Press of a Button

- Doors stay open – and the Ovention Shuttle has the same throughput as a high performance conveyor during peak periods

## Unparalleled Features Common to Both Modes:

### Fast – but without Microwaves!

### No Hood Required

- Ovention's revolutionary closed cooking system surpasses UL grease emissions standards

### Drastically Reduced Energy Costs

- Unique door system minimizes hot air escape
- Reduced oven energy consumption
- Reduced air extraction / HVAC costs

### Quiet!

- Makes far less noise than a conveyor oven

### Smaller Kitchen Footprint

- One Ovention Shuttle can replace multiple pieces of cooking equipment – such as a countertop conveyor and convection oven

# Ovention Shuttle – The Solution for Your Menu Challenges

## Shuttle S2000 Specifications

**Height:** 20.25" (514.3 mm)  
**Width:** 56.88" (without extensions) (1444.75 mm)  
**Depth:** 36.22" (919.9 mm)  
**Oven Weight:** 240 lbs.

	S2000	S20003PH
<b>Power:</b>	1 Phase 60 Hz	3 Phase 60 Hz
<b>Operating Voltage:</b>	208V	240V
<b>Max Current Draw (per phase):</b>	45 Amps	34 Amps
<b>Watts:</b>	9.2 kW/11.8kW	12.6 kW/14.7kW
<b>Plug:</b>	NEMA 6-50P	NEMA 15-50P
<b>Cord Length:</b>	72"	72"

### Ventilation:

UL197 (KNLZ) listed for ventless operation  
 EPA202 Tested from Section 59 of UL710B (8 hr)  
**Product:** Pepperoni Pizza

**Results:** 2.01 mg/m<sup>3</sup>

Internal catalytic filtration to limit smoke, grease, and odor emissions

### Shipping Information:

**Freight Class:** 150  
**Cube:** 68" x 41" x 30"  
**Shipping Weight:** 325 lbs.  
**FOB:** Sturgeon Bay, Wisconsin

Measurement Units: Inches (Millimeters)

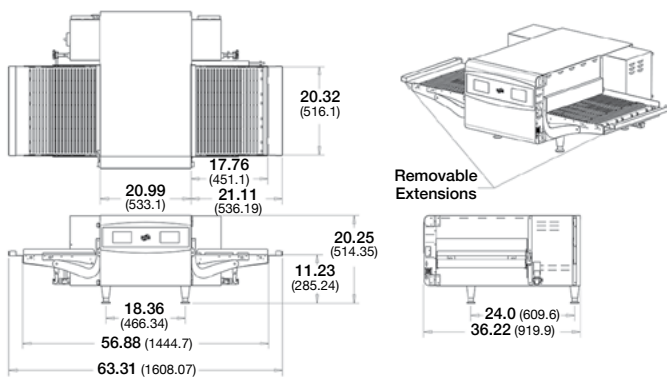

## Shuttle S1200 Specifications

**Height:** 20.21" (513.38 mm)  
**Width:** 43.83" (1113.3 mm)  
**Depth:** 30.80" (782.3 mm)  
**Oven Weight:** 180 lbs.  
**Power:** Single Phase 60 Hz  
**Operating Voltage:** 208V / 240V  
**Max Current Draw:** 26A  
**Plug:** NEMA 6-30P  
**Cord Length:** 72" (1828.8 mm)

### Ventilation:

UL197 (KNLZ) listed for ventless operation  
 EPA202 Tested from Section 59 of UL710B (8 hr)

**Product:** Pepperoni Pizza

**Results:** 2.01 mg/m<sup>3</sup>

Internal catalytic filtration to limit smoke, grease, and odor emissions

### Shipping Information:

**Freight Class:** 150  
**Cube:** 68" x 41" x 30"  
**Shipping Weight:** 250 lbs.  
**FOB:** Sturgeon Bay, Wisconsin

Measurement Units: Inches (Millimeters)

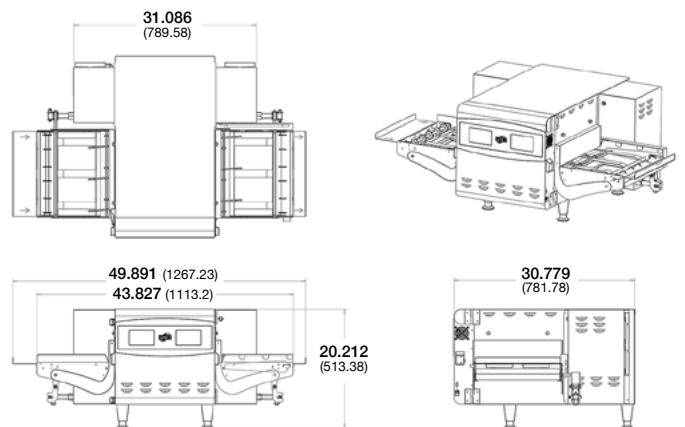

OVENTION, INC.

635 South 28th Street • Milwaukee, Wisconsin 53215

Call Toll Free 855.298.OVEN • [www.OventionOvens.com](http://www.OventionOvens.com) • Email: [connect@OventionOvens.com](mailto:connect@OventionOvens.com)