

REFRIGERATOR MANUFACTURER
Turbo air
 more durable, efficient, beautiful

4184 E. Conant St.
 Long Beach, CA 90808
 Tel. 310-900-1000
 Fax. 310-900-1077
www.turboairinc.com

| | |
|-----------------|-------|
| Project : | |
| Model # : | |
| Item # : | Qty : |
| Available W/H : | |
| Approval : | |

Chef Base Freezer

*Chef Bases
 PRO Series*

Patented Self-Cleaning Condenser



This product is equipped with a fine mesh filter to the front of the condenser to catch dust, and a rotating brush that moves up and down daily to remove excess buildup outward and away.

Model : PRCBE-60F-N



* Each drawer accommodates up to 6" deep sixth (1/6) size pans (drawer pans not included)

≡ FEATURES & BENEFITS ≡

■ Self-Cleaning Condenser

The accumulation of dust in the condenser can cause the failure or breakdown of refrigerators. Refrigerators run normally until they reach a certain level of accumulation. At some point, when they are over the limit, their performance drops quickly resulting in damage to, or disposal of the stored products inside. The Self-Cleaning Condenser device keeps the condenser clean and prevents system failure by automatically brushing daily.

■ Hydrocarbon refrigerants (R-290)

With innovative and eco-friendly technology, Turbo Air brings you hydrocarbon refrigerators designed to meet DOE's Energy Conservation Standards in 2017 and to use EPA's SNAP Program approved HC refrigerants. Hydrocarbon refrigerants do not deplete the ozone layer and have very low contribution to global warming (ODP-0, GWP-3).

■ Digital temperature display on front panel

■ Strong body and durable construction

Built with heavy duty 16 ga. stainless steel, Chef Base top is manufactured of one-piece reinforced stainless steel to ensure durability.

■ Countertops

PRCBE-48/60R-N supports up to 788 pounds of equipment.
 PRCBE-72/84R-N supports up to 1,192 pounds of equipment.

■ Durable stainless steel drawers

■ Top is insulated to eliminate heat transfer to the interior of cabinet

■ Front breathing design for easy maintenance and zero-clearance installation

With compressors positioned on the side of the unit, our refrigerators can now be serviced without being moved. Our innovative, front breathing feature also allows this model to be highly efficient in narrow spaces.

■ High-density polyurethane insulation

The entire cabinet structure and solid doors are foamed-in-place using high density, CFC free polyurethane insulation.

■ Stainless steel top with Drip Guard (marine) edge

■ Hot gas condensate system

■ Full length drawer with gasket guard

■ Drawer slider load capacity up to 180 lbs

■ Magnetic snap-in gasket

■ Freezer holds -10°F ~ 0°F for the best in frozen food preservation



| Model | Drawers | CU./FT. | Pans Capacity (in.) (# of pans) | HP | AMPS | Crated Weight (lbs.) | L x D x H* (inches) |
|--------------------|----------|-------------|------------------------------------|------------|------------|-------------------------|-----------------------------|
| PRCBE-60F-N | 2 | 9.77 | 127/8 x 20 x 6 (6) | 3/8 | 6.4 | 377 | 60 x 33 1/2 x 21 5/8 |

Model : PRCBE-60F-N

| ELECTRICAL DATA | |
|--------------------------------|--|
| Voltage | 115/60/1 |
| Plug Type |  NEMA 5-15P |
| Full Load Amperes | 6.4 |
| Compressor HP | 3/8 |
| Cord Length (ft.) | 9 |
| Refrigerant | R-290 |
| DIMENSIONAL DATA | |
| Ext. Length Overall (in.) | 60 (1525mm) |
| Ext. Depth Overall (in.) | 33 1/2 (852mm) |
| Ext. Height Overall (in.)* | 21 5/8 (550mm) |
| # of Drawers | 2 |
| Pans Capacity (in.)(# of pans) | 12 7/8 x 20 x 6 (6) |
| Net Capacity (cu. ft.) | 9.77 |
| Net Weight (lbs.) | 322 |
| Gross Weight (lbs.) | 377 |

Design and specifications subject to change without notice.
Actual shipping weight may differ due to extra packing materials for product protection.
* Height does not include 5" for caster height.

■ **WARRANTY : 3 Year Parts and Labor Warranty
Additional 2 Year Warranty on Compressor**

■ **STANDARD FEATURES**

- *Anti-corrosion coated evaporator*
- *Self-contained system*
- *4" dia. swivel casters standard*

■ **OPTIONAL ACCESSORIES**

- 1" caster, 1/2" diameter & 13 TPI: S28R813660 (non-brake)
- 2.5" caster, 1/2" diameter & 13 TPI: 30265H0100 (non-brake), 30265H0200 (w/ brake)
- 5" caster, 1/2" diameter & 13 TPI: M726500100 (non-brake), M726500200 (w/ brake)
- Leveling leg, 1/2" - 13 TPI x 1.54": LFM1213566
- 6" ABS plastic leg: 30221M0200
- 6" stainless steel leg: 30221M0600
- Condensing unit on the right available
 - * Please allow lead time for shipping. Please contact factory for more details.

PLAN VIEW

(unit : inch)

* Each drawer accommodates up to 6" deep sixth (1/6) size pans (drawer pans not included)

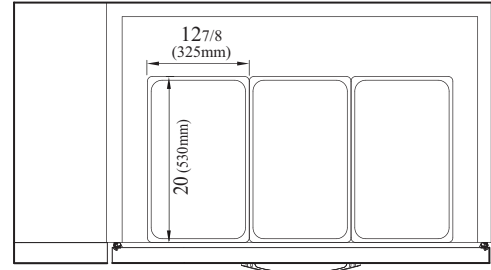

TOP VIEW

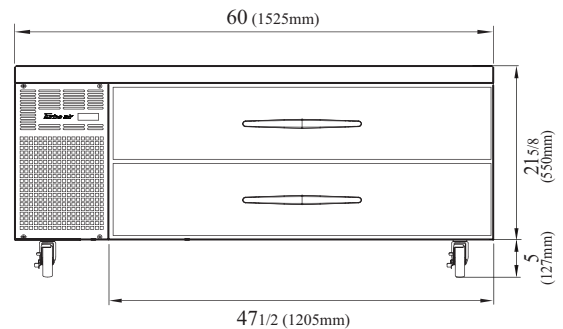

FRONT VIEW

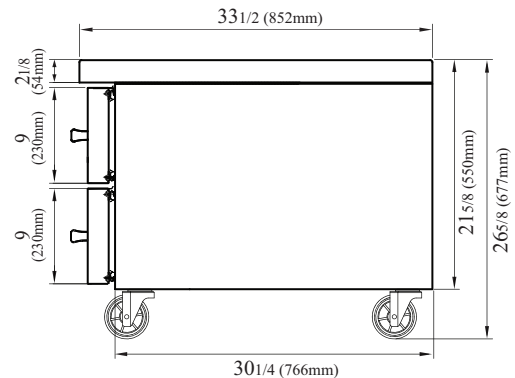

SIDE VIEW

Ver.20190812



- Turbo Air : 800-627-0032
- GK : 800-500-3519
- Warranty : 800-381-7770
- AC : 888-900-1002

