

➤ **1" H x 1½" W Aluminum Slides**

Welded to Frame

➤ **Holds**

Standard 18" x 26" Sheet Pans

➤ **5" Swivel Stem Casters (CV)**

➤ **"KD" Knock Down Rack**

Ships UPS in One Box
Easy Assembly

➤ **"W" All Welded Rack**

Reinforced Gusset Corners
Ships LTL

➤ **Optional**

- Locking Casters (CL)
- Heavy-Duty Swivel Casters (CHV)
- Heavy-Duty Locking Casters (CHL)
- Pan Stop (PS)
- Covers
 - End Load (VYRE-T)
 - Side Load (VYRS-T)

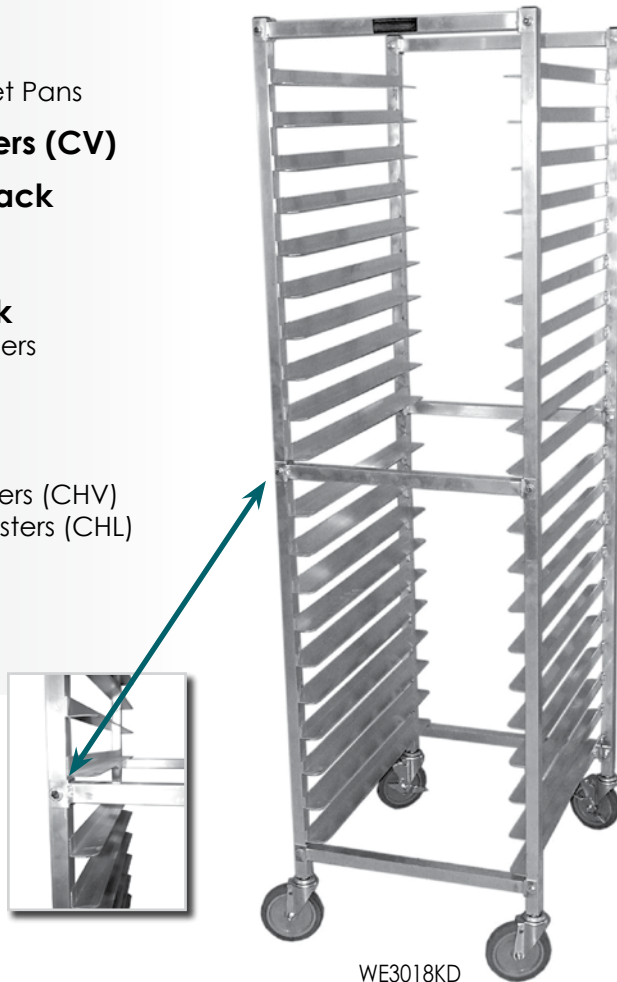

WE3018KD

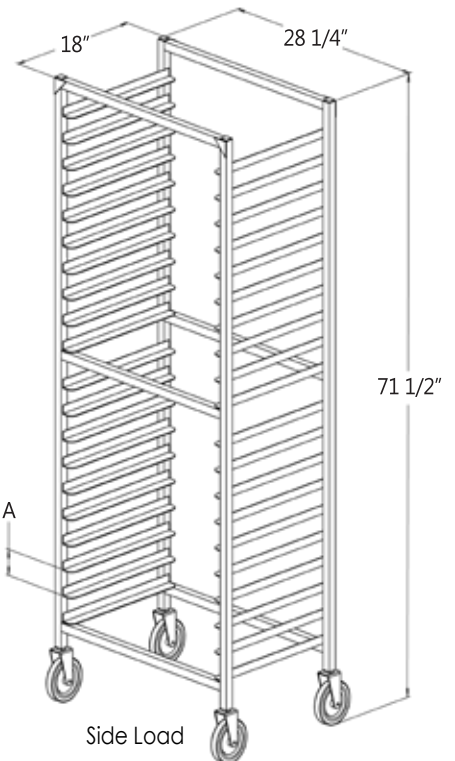
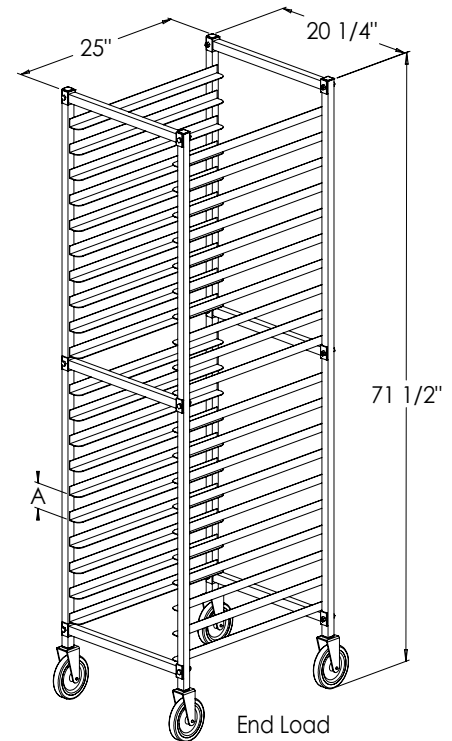

W-Series Welded & "KD" Knock Down Pan Racks

Model Number	Add to Suffix	Description	"A" Shelf Spacing	Pan Capacity
WE2018	KD W	End Load	2"	30
WE3018	KD W	End Load	3"	20
WE4018	KD W	End Load	4"	15
WE5018	KD W	End Load	5"	12
WE6018	KD W	End Load	6"	10
WS2026	KD W	Side Load	2"	30
WS3026	KD W	Side Load	3"	20
WS4026	KD W	Side Load	4"	15
WS5026	KD W	Side Load	5"	12
WS6026	KD W	Side Load	6"	10

Options: "CL", "CHV", "CHL", "PS" - see page 77 for details.

Optional Covers: see page 75 for specifications - call for quote.