

- **Organize, Store & Transport Foods**
- **1" H x 1½" W Aluminum Slides**
Welded to Frame
- **Holds**
18" x 26" or 18" x 13" Poly Food Boxes
Manufactured by Cambro®, Carlisle®,
Continental® or Rubbermaid®
- **5" Swivel Stem Casters (CV)**
- **All Aluminum – Will Not Rust**
- **"KD" Knock Down Rack**
Ships UPS in One Box
Assembles with 12 Fasteners
- **"W" All Welded Rack**
Reinforced Gusset Corners
Ships LTL
- **Optional**
Locking Casters (CL)
Heavy-Duty Swivel Casters (CHV)
Heavy-Duty Locking Casters (CHL)
Pan Stop (PS)
Cover (VYRE-C)

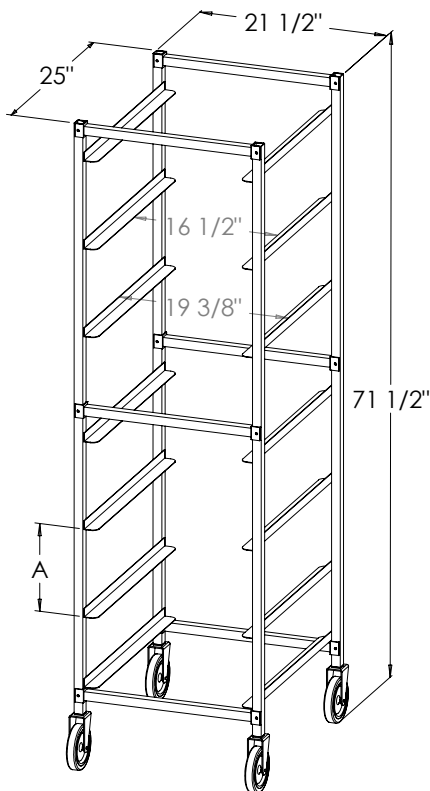

Poly Box Storage Racks			
Model Number	Description	"A" Shelf Spacing	Pan Capacity
WE40195KD-PB	"KD" End Load	4"	14
WE70195KD-PB	"KD" End Load	7"	7
WE10195KD-PB	"KD" End Load	10"	6
WE40195W-PB	All Welded End Load	4"	14
WE70195W-PB	All Welded End Load	7"	7
WE10195W-PB	All Welded End Load	10"	6



Options: "CL", "CHV", "CHL", "PS" - see page 77 for details.