

- **Space-Saving Design**
May be Loaded when Nested
Great for Storage
- **Heavy Load Capacity**
- **Heavy-Duty 1/8" Thick Aluminum**
- **Easy Clean Design**
Compared to Plastic or Wire
- **Optional**
Plastic Feet Caps(DRCAP)



**EASY
CLEAN**



DR2024-8



DR1848 (x3)
Shows Nesting Ability



8" Leg Nesting Dunnage Racks

Model Number	Footprint W x L	Wt.
DR1824-8	17 1/4" x 23 1/4"	7
DR1836-8	17 1/4" x 35 1/4"	8
DR1848-8	17 1/4" x 47 1/4"	10
DR1860-8	17 1/4" x 59 1/4"	13
DR2024-8	19 1/4" x 23 1/4"	9
DR2036-8	19 1/4" x 35 1/4"	10
DR2048-8	19 1/4" x 47 1/4"	12
DR2060-8	19 1/4" x 59 1/4"	14
DR2424-8	23 1/4" x 23 1/4"	12
DR2436-8	23 1/4" x 35 1/4"	13
DR2448-8	23 1/4" x 47 1/4"	14
DR2460-8	23 1/4" x 59 1/4"	15



12" Leg Nesting Dunnage Racks

Model Number	Footprint W x L	Wt.
DR1824	18" x 24"	7
DR1836	18" x 36"	8
DR1848	18" x 48"	10
DR1860	18" x 60"	13
DR2024	20" x 24"	9
DR2036	20" x 36"	10
DR2048	20" x 48"	12
DR2060	20" x 60"	14
DR2424	24" x 24"	12
DR2436	24" x 36"	13
DR2448	24" x 48"	14
DR2460	24" x 60"	15

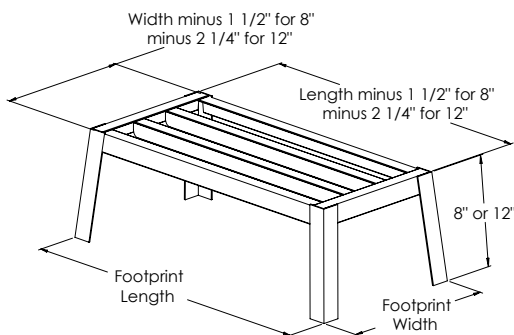

Options: "DRCAP" - see page 78 for details.

Options: "DRCAP" - see page 78 for details.