

- **Ideal for Catering**
Great for Loading and Unloading into Facility
- **Extended Hook to Clear Rear Bumper**
- **Heavy Duty, Welded Construction**
Reinforced Underside Tubing for Added Strength
- **Lightweight, Durable Aluminum**
– Will Not Rust
- **Anti-Slip, High Traction Surface**
- **Folds and Carries Like a Suitcase**
Separates into Two Pieces for Easy Carrying

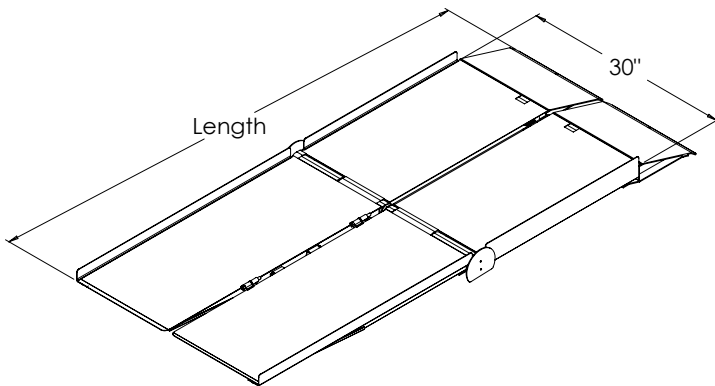
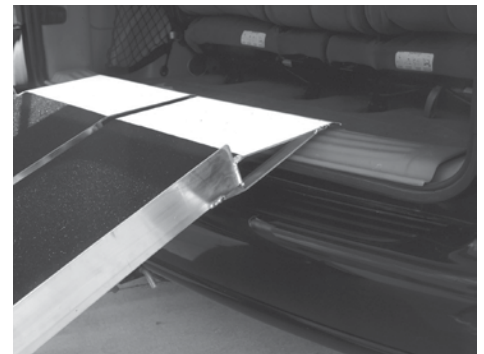

Utility Ramps				
Model Number	Size L x W	Folded Size W x H x L	Weight	Weight Capacity
UTW630	6' x 30"	10 ³ / ₄ " x 16" x 38 ¹ / ₄ "	36	600 lbs.
UTW730	7' x 30"	10 ³ / ₄ " x 16" x 44 ¹ / ₄ "	41	600 lbs.
UTW830	8' x 30"	11" x 16" x 50 ³ / ₄ "	52	600 lbs.
UTW1030	10' x 30"	11" x 16" x 62 ³ / ₄ "	63	500 lbs.

Maximum Ramp Capacity: 300 lbs - One axle, 600 lbs - Two axles. Except on UTW1030: 250 lbs - One axle, 500 lbs - Two axles.