

- **Available in 36" and 48" Wide Models with Under Shelf and Cantilever Shelf**
- **16 Gauge Stainless Steel Construction**
- **Space Saver**
Folds Up to be Moved and/or Stored for Easy Clean Up
- **Work Surface Weight Capacity - 500 lbs. (Evenly Distributed Load)**
- **24" Deep Work Surface with 1 3/4" Backsplash on Three (3) Sides**
- **Safety Pins Provided for Added Security**
- **Prep Station Mounts to Caster Base**
Minimal Assembly Required
Four (4) 3" x 1 1/4" Swivel Locking Casters (CDL3)



RTW246036C
(Closed)

Add additional work or prep space when you need it...and floor space when you don't!



RTW246036C
(Open)

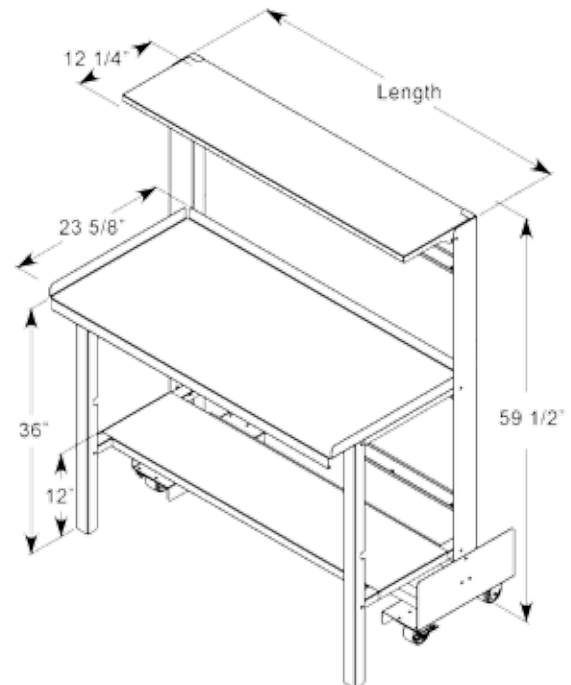

Mobile Retractable Prep Stations

Model Number	Closed Size D x H x W	Opened Size D x H x W	Weight
RTW246036C	17" x 60" x 36"	24" X 60" X 36"	94
RTW246048C	17" x 60" x 48"	24" X 60" X 48"	112