

- **Available in 36" and 48" Wide Models with Under Shelf and Cantilever Shelf**
- **16 Gauge Stainless Steel Construction**
- **Space Saver**
Folds Up to be Moved and/or Stored for Easy Clean Up
- **Work Surface Weight Capacity - 500 lbs. (Evenly Distributed Load)**
- **24" Deep Work Surface has 1 3/4" Backsplash on Three (3) Sides**
- **Safety Pins Provided for Added Security**
- **Wall Mount Model Comes Fully Assembled**
With Mounting Hardware for Drywall and Stud Installation
Mounts 6" off the Floor
- **Make Unit Mobile by Adding Optional Caster Base***
Minimal Assembly Required
Four (4) 3" x 1 1/4" Swivel Locking Caster (CDL3)

*See page 34 for more information on mobile units



RTW246036
(Open)

Add additional work or prep space when you need it...and floor space when you don't!

RTW246036
(Closed)

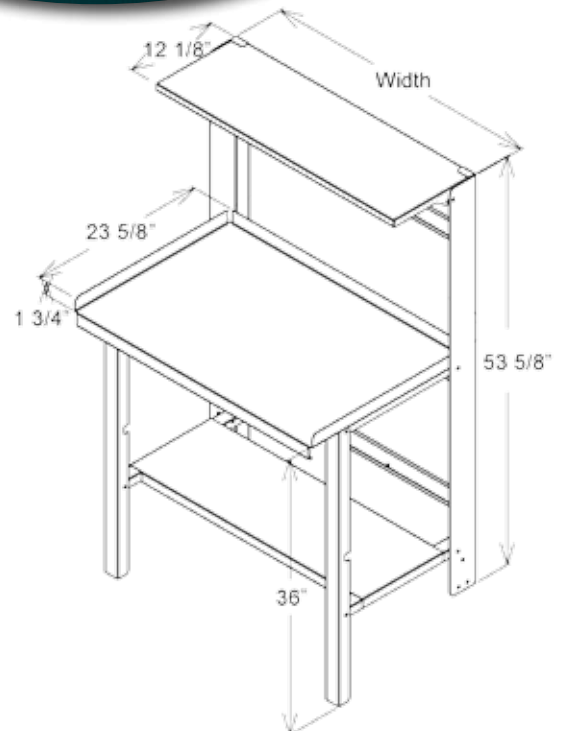

24" Retractable Prep Stations

Model Number	Closed Size* D x H x W	Opened Size D x H x W	Weight
RTW246036	5 1/4" x 60" x 36"	24" X 60" X 36"	68
RTW246048	5 1/4" x 60" x 48"	24" X 60" X 48"	82

*Closed height is measured from floor level to top of product.

Optional Caster Bases

Model Number	Description
RT36C	36" Caster Base; Compatible with RTW246036
RT48C	48" Caster Base; Compatible with RTW246048