

➤ **1" H x 1½" W Welded Aluminum Slides**

1" H x 1½" W

➤ **Holds Following Pan Sizes by the Lip**

Full Size 20¾" x 12¾"

Half Size 10¾" x 12¾"

Two-Third Size 13⅞" x 12¾"

One-Third Size 6⅞" x 12¾"

➤ **5" Swivel Stem Casters (CV)**

➤ **"KD" Knock Down Rack**

Ships UPS in One Box

Assembles with 12 Fasteners

➤ **"W" All Welded Rack**

Reinforced Gusset Corners

Ships LTL

➤ **Optional**

Locking Casters (CL)

Heavy-Duty Swivel Casters (CHV)

Heavy-Duty Locking Casters (CHL)

Pan Stop (PS)



WE3020KD-SP

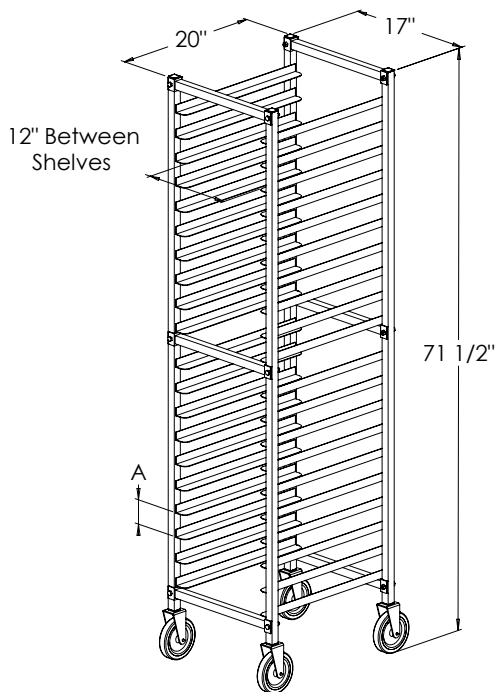

Steam Table Pan Racks			
Model Number	Description	"A" Shelf Spacing	Pan Capacity
WE3020KD-SP	"KD" End Load	3"	18
WE5020KD-SP	"KD" End Load	5"	10
WE3020W-SP	All Welded End Load	3"	18
WE5020W-SP	All Welded End Load	5"	10

Options: "CL", "CHV", "CHL", "PS" - see page 77 for details.