

➤ **1" H x 1½" W Aluminum Slides**

Welded to Frame

➤ **Holds**

Standard 18" x 26" Sheet Pans

➤ **5" Swivel Stem Casters (CV)**

➤ **"KD" Knock Down Rack**

Ships UPS in One Box

Assembles with 8 Fasteners

➤ **"W" All Welded Rack**

Reinforced Gusset Corners

Ships UPS

➤ **Optional**

Locking Casters (CL)

Heavy-Duty Swivel Casters (CHV)

Heavy-Duty Locking Casters (CHL)

Pan Stop (PS)

Covers (VYRE.25)

Tops: Poly, Stainless or Aluminum (PT, ST, AT)



WE3018-7W-ST
(Shown with optional stainless top)

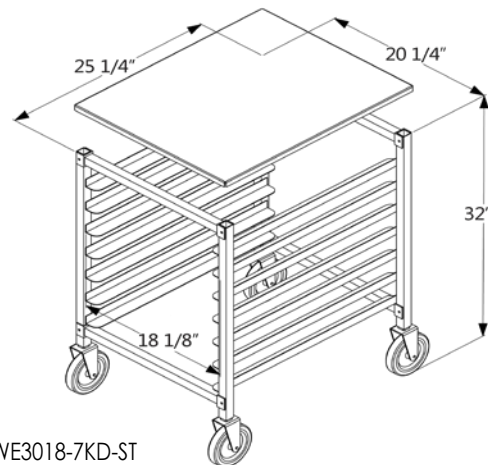

WE3018-7KD-ST
(Shown with optional stainless top)



W-Series Half Size Pan Racks

Model Number	Description	Shelf Spacing	I.D. Width	O.D. D x W x L	Pan Capacity	Weight #
WE3018-7KD	"KD" End Load	3"	18 1/8"	25 1/4" x 20 1/4" x 32"	7	15
WE3018-7W	All Welded End Load	3"	18 1/8"	25 1/4" x 20 1/4" x 32"	7	15
WS3026-7KD	"KD" Side Load	3"	26 1/8"	18 1/4" x 28 1/4" x 32"	7	23
WS3026-7W	All Welded Side Load	3"	26 1/8"	18 1/4" x 28 1/4" x 32"	7	22

Options: "CL", "CHV", "CHL", "PS", "PT", "ST", "AT" - see page 77 & 78 for details.

Optional Covers: see page 75 for specifications - call for quote.