

- ▣ **Built for Years of Service**
 One-Piece Easy Grip Handle and Legs
- ▣ **All Welded - 300 Series Stainless Steel Construction**
- ▣ **16 Gauge Shelves**
 1½" High Splash Guard on Three (3) Sides
- ▣ **5" Swivel Stem Casters (CV)**
- ▣ **I.D. 18" x 30" Shelves - Top Shelf at 36" Height**
- ▣ **Ships LTL**
- ▣ **Optional**
 Locking Casters (CL)
 Heavy-Duty Swivel Casters (CHV)
 Heavy-Duty Locking Casters (CHL)

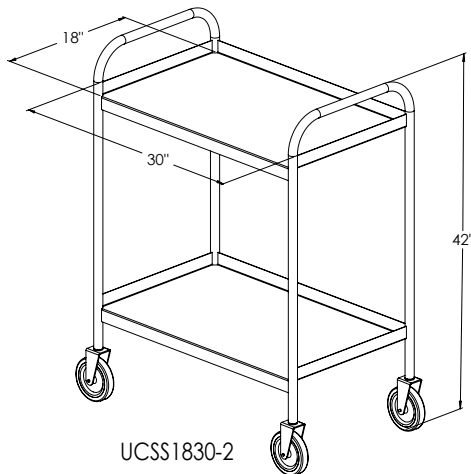

UCSS1830-2

BUILT TO LAST



UCSS1830-2

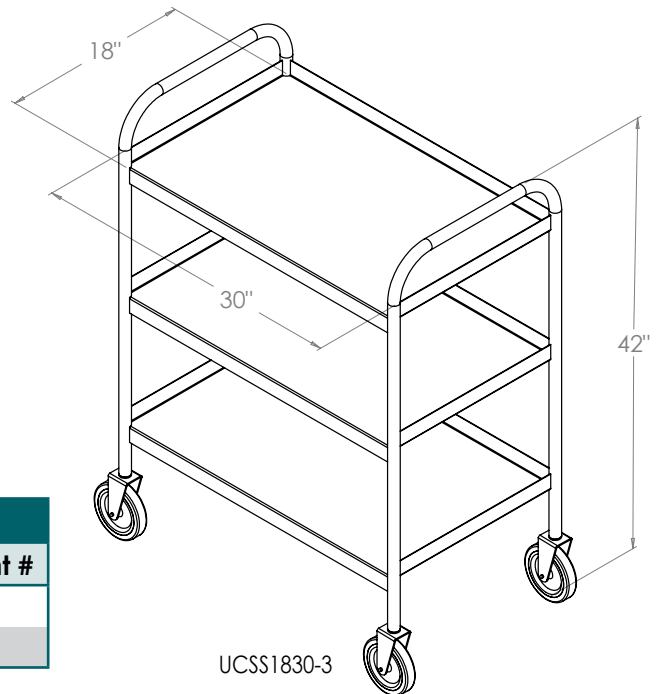

UCSS1830-3

Stainless Steel Utility Carts			
Model Number	Description	O.D. Size W x H x L	Weight #
UCSS1830-2	2 Shelves	19" x 42" x 31"	42
UCSS1830-3	3 Shelves	19" x 42" x 31"	42

Options: "CL", "CHV", "CHL" - see page 77 for details.