



Project:

Item Number:

Quantity:

**F231-2X GRAVITY FED TWIN TWIST FLOOR MODEL WITH LARGE CAPACITY HOPPER**



**DESCRIPTION**

Stoelting's Gravity Soft Serve Freezer dispenses two single flavors, or combines them in a twin twist. The F231-2X has 66% larger storage capacity than the standard F231. Each hopper can hold up to five gallons of mix.

This freezer is ideal in self-serve and buffet-style restaurants or any location seeking the convenience of less frequent hopper refills.

 Every machine includes Stoelting's White Glove Service. One call does it all – customer service, technical service, parts or warranty information, installation, startup, sales, on-site service dispatch and much more. Available 24 hours a day, seven days a week year-round.

Continuous research leads to ongoing product improvements; therefore, these specifications are subject to change without notice and should not be used as installation specifications.

**ITEMS**

Item No.	Description
<input type="checkbox"/> F231-3812-2X	Air Cooled, Single Phase
<input type="checkbox"/> F231-30912-2X	Air Cooled, Three Phase

**MIX INLET REGULATOR - (REQUIRED)**

Two required, one per barrel.

- 2149243-01** 2A 3/16" Standard.
- 2204806** Adjustable.

**FEATURES**

- Delrin® food grade plastic blades provide quiet operation and superior durability.
- Simplified design for quick assembly after cleaning.
- Adjust the dispense rate to meet your requirements.
- Clear door displays circulating product for merchandising appeal.
- Efficient freezing cylinder and auger design delivers a consistent uniform product with small ice crystals and a quick recovery time.
- Highly efficient auger design gently folds the entire contents of the freezing cylinder, delivering a thick, smooth, and creamy product.
- Self-closing spigot eliminates waste and ensures precise portion control.
- Long-wearing parts offer lower preventative maintenance costs.
- Organized hopper covers have compartments for all parts in the freezing cylinder. The hopper covers help with parts identification and prevent loss of parts.

**IntelliTec2™ Control**

- Programmable and configurable through multi-line graphics display
- Upload firmware and download statistics through a USB connection.
- Performance and error logs provide data to maximize profitability
- Senses product consistency or temperature to customize for a wide variety of mixes
- Standby and sleep modes conserve energy and automatically defrost product, maintaining small ice crystals and delivering a superior mouthfeel

**ADA Compliant Handles (Optional)**

- Flat handles 48" from ground

Approvals	Date

## F231-2X GRAVITY FED TWIN TWIST FLOOR MODEL WITH LARGE CAPACITY HOPPER

### DIMENSIONS (Shown in inches (cm))

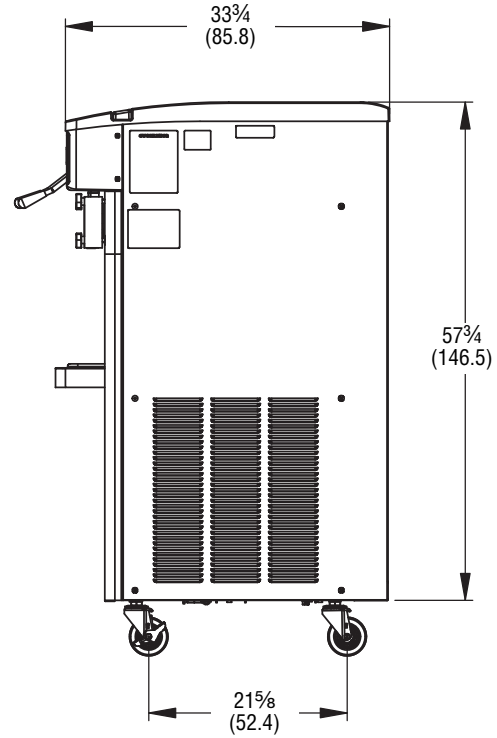
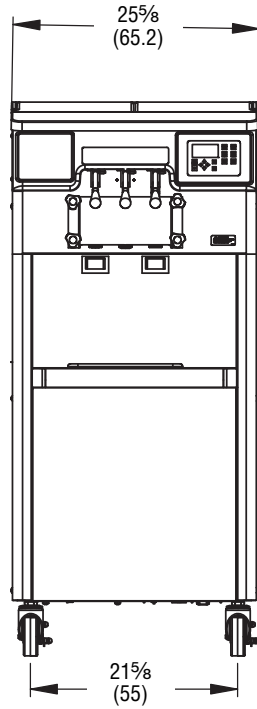

- Requires a dedicated electrical circuit.
- Indoor use only.
- Maximum ambient temperature: 100°F (37.8 °C).
- Minimum clearance of 3" (7.6 cm) air space on both sides and open at the top.

### GENERAL SPECIFICATIONS

Freezing Cylinder			Hopper				Weight lb (kg)	Crated Weight lb (kg)
Capacity gallon (L)	Compressor Btu/hr	Refrigerant	Drive Motor (hp)	Capacity gallon (L)	Compressor Btu/hr	Refrigerant		
Two 0.85 (3.22)	12,000	R-404A	Two 3/4	Two 5 (18.9)	1,300	R-134a	640 (290.2)	730 (331.1)

### ITEM NUMBER SPECIFICATIONS

Item No.	Cooling	ADA Handles	Volts	Phase	Hz	Plug
F231-3812-2X	Air	✓	208-240	1	60	NEMA 6-20P
F231-30912-2X				3		NEMA L15-20P



**Service Information**  
 800-319-9549 (U.S. Toll Free)  
 920-894-2293 (Outside the U.S.)  
 www.stoeltingfoodservice.com  
 www.vollrath.com