

PUMPS: POUCHED PRODUCTS EXPRESS™ MULTIPLES

Models SE-2, SE-2DI, SE-3, SE-3DI, SE-4, SE-4DI, SE-5 & SE-5DI

WHAT DO YOU DISPENSE?

- ◊ **THIN** • fountain syrups • liqueur • hot or soy sauce
- **THICK** • ketchup • mustard • mayo • bbq sauce
- **PARTICULATES** • tartar sauce • Thousand Island



◊●● SE-3DI 07050



◊●● SE-4 07200

BID DESCRIPTION

Server Express™ multiples are constructed of a brushed (#4) finish stainless steel base and lid with surgical-quality plastic pumps. Dispensing levers are black polypropylene.

Capacity is 1½ gallons (or 6 L) per pouch. Pumps yield 1 ounce (30 mL) per stroke with portion control to reduce the yield in ¼ ounce (7 mL) increments. Exclusively uses pouches with 16 mm fitment. The Server Express™ System achieves up to 98% evacuation.

Server Express™ Rails are available for countertop and drop-in applications with (2), (3), (4) or (5) pumps. Drop-in rails are assigned a "DI" suffix in the model name.

STANDARD FEATURES

- Pump several condiments from one space-saving unit
- Holds 1½ gallon (or 6 L) pouches with 16 mm fitment
- New Server pump is constructed of surgical-quality plastic parts — quick to breakdown and completely dishwasher safe
- Pump is ADA compliant, requiring less than 5 lbs of pressure to dispense
- Maximum stroke yields 1 ounce (30 mL)
- Easy-to-adjust portion control in ¼ ounce (7 mL) increments
- Discharge tube fitting — new design works with ketchup, mustard and mayonnaise

ACCESSORY ITEMS

- Replacement Pump 07794
- Triple Drip Tray Assembly 07295
- Quad Drip Tray Assembly 07324
- Quintuple Drip Tray Assembly 07299



ADA
compliant



2
YEAR
WARRANTY

TWO YEAR WARRANTY

Server Products equipment is backed by a two-year limited warranty against defects in materials and workmanship. For a copy of our complete warranty statement, please refer to server-products.com.

CAD LIBRARY

Individual CAD images can be downloaded free of charge from our website. Our complete collection of CAD files, along with more than 100 other manufacturers, can be purchased through Kochman Consultants, Ltd. at kclcad.com.

PUMPS: POUCHED PRODUCTS EXPRESS™ MULTIPLES

Models SE-2, SE-2DI, SE-3, SE-3DI, SE-4, SE-4DI, SE-5 & SE-5DI

SERVER EXPRESS™ - COUNTERTOP

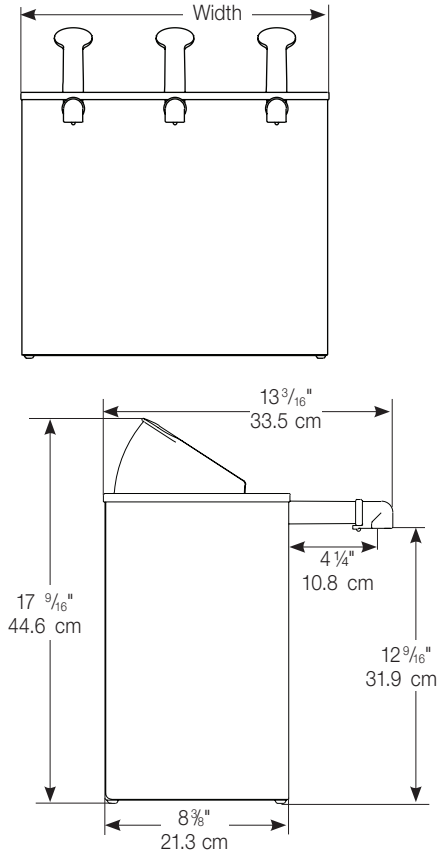

SERVER EXPRESS™ - DROP-IN

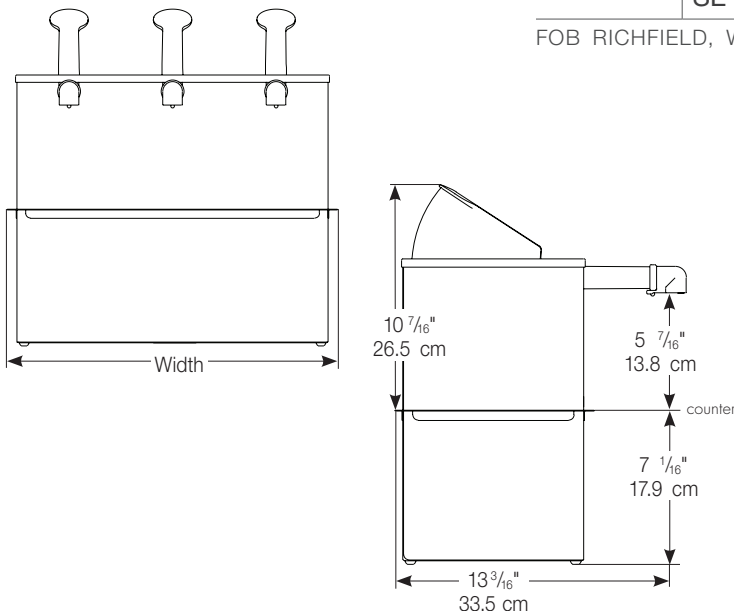

MODELS ☉☉☉	SE-2 07140	SE-3 07040	SE-4 07200	SE-5 07060
Capacity <small>Per pump section</small>	1½ gal 6 L	1½ gal 6 L	1½ gal 6 L	1½ gal 6 L
Height	17½" 44.5 cm	17½" 44.5 cm	17½" 44.5 cm	17½" 44.5 cm
Width	11" 27.9 cm	16 ⅜" 41.6 cm	21 ⅓" 55.4 cm	27 ⅜" 69.1 cm
Depth	13 ⅝" 33.8 cm	13 ⅝" 33.8 cm	13 ⅝" 33.8 cm	13 ⅝" 33.8 cm
Weight	15 lb 6.8 kg	18 lb 8.2 kg	22 lb 9.8 kg	34 lb 15.4 kg
MODELS ☉☉☉	SE-2DI 07160	SE-3DI 07050	SE-4DI 07210	SE-5DI 07070
Capacity <small>Per pump section</small>	1½ gal 6 L	1½ gal 6 L	1½ gal 6 L	1½ gal 6 L
Height	10 ⅞" 26.5 cm	10 ⅞" 26.5 cm	10 ⅞" 26.5 cm	10 ⅞" 26.5 cm
Width	11 ⅞" 30.2 cm	17 ¼" 43.8 cm	22 ⅞" 57.6 cm	28 ⅞" 71.3 cm
Depth	13 ¾" 6.8 cm	13 ¾" 6.8 cm	13 ¾" 6.8 cm	13 ¾" 6.8 cm
Weight	15 lb 6.8 kg	19 lb 8.6 kg	22 lb 9.8 kg	34 lb 15.4 kg
Cutout Size	SE-2DI: 11" x 8½" (27.9 X 21.6 cm) SE-3DI: 16 ⅜" x 8½" (41.6 x 21.6 cm) SE-4DI: 21 ⅓" x 8½" (55.4 x 21.6 cm) SE-5DI: 27 ⅜" x 8½" (69.1 x 21.6 cm)			

FOB RICHFIELD, WISCONSIN 53076