

FWR Floor Water Receptacle Standard Design

SPECIFICATION:

FWR Model Floor Water Receptacles are 16-gauge type 304 stainless steel one-piece construction. Horizontal corners are coved and the trough is integrally pitched toward a waste outlet with a stainless steel beehive strainer and a 4" OD tailpiece.

Recessed flange and 1" deep ledge for IMC grating are integral with the unit. Unit is 7 1/2" wide and 4" deep.

Joints are TIG welded and leak-proof. Exposed surfaces finished brush satin.

PRODUCT GUIDE:

Use for Commercial and Institutional Buildings or large food prep facilities.

Unit is generally used underneath Ice Machines or in front of walk-ins or large water discharge areas, in tight spaces.

Flexible design such as custom depths make this a versatile drain trough.

Recessed flange supports floor tile and provides a grout pocket.

Setting frame for waterproof membrane and/or integral seepage flange with "weep" holes can be added for wet floor areas.

Extension arms and intersections available for multiple equipment layout.

OPTIONS:

- 12 or 14-gauge stainless steel
- Use with most IMC trough grating
- Custom designs, sizes and waste location. Shallow 2" deep available
- Optional waste locations
- Seepage flange and "weep" holes
- See Price Book for other options
- Standard and stock sizes fit most applications
- Anti-Splash Design

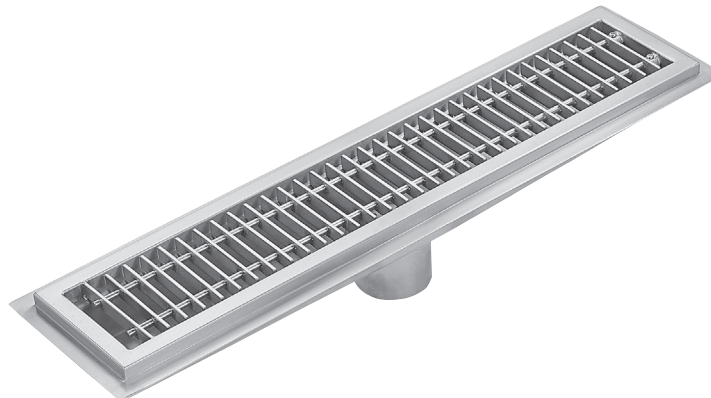

*Price page 49

Specifications subject to change without notice.



P.O. Box 206
Copliague, NY 11726-0206

800-221-5644/631-789-8881
Fax: 631-789-3633

FWR-30 1007

www.imcteddy.com

FWR Floor Water Receptacle Standard Design

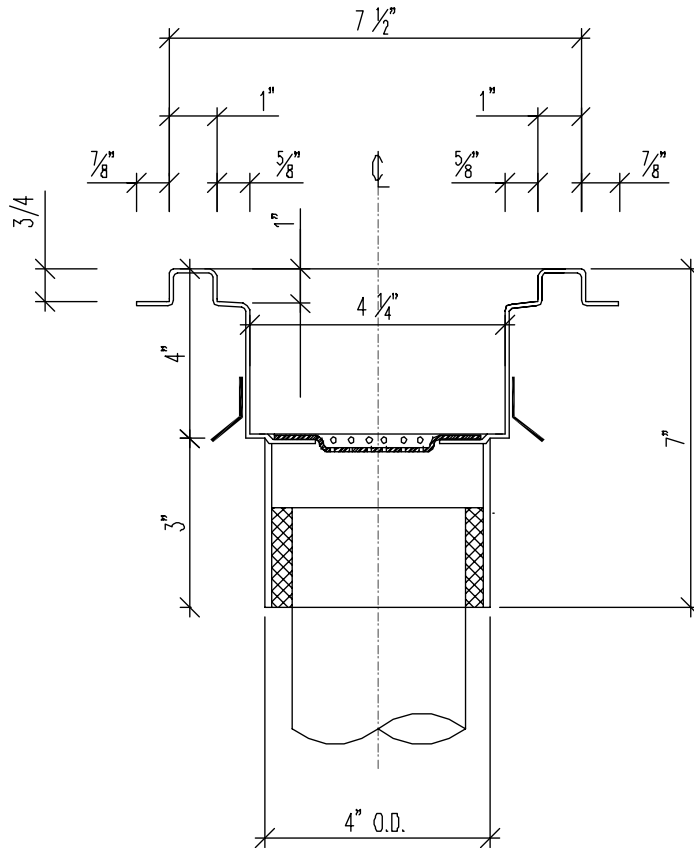

FLOOR WATER RECEPTACLES, STANDARD DESIGN - 4" Deep

MODEL	SIZE (W x L)	METRIC	WEIGHT
FWR-24	7 1/2" x 24"	191 x 610	20
FWR-30	7 1/2" x 30"	191 x 762	25
FWR-36	7 1/2" x 36"	191 x 914	30
FWR-42	7 1/2" x 42"	191 x 1067	35
FWR-48	7 1/2" x 48"	191 x 1219	40
FWR-54	7 1/2" x 54"	191 x 1372	45
FWR-60	7 1/2" x 60"	191 x 1524	50
FWR-72	7 1/2" x 72"	191 x 1829	60
FWR-84	7 1/2" x 84"	191 x 2134	70
FWR-96	7 1/2" x 96"	191 x 2438	80
FWR-108	7 1/2" x 108"	191 x 2743	90
FWR-120	7 1/2" x 120"	191 x 3048	100

Note - Standard troughs up to 96" have one (1) waste at center. Over 96", troughs have two (2) wastes equidistant.

*See Price book page 49 & 59-60 for additional sizes and options.

Specifications subject to change without notice.



P.O. Box 206
Copliague, NY 11726-0206

800-221-5644/631-789-8881
Fax: 631-789-3633

www.imcteddy.com

FWR-30 1007