



Project _____
 AIA # _____ SIS # _____
 Item # _____ Quantity _____ C.S.I. Section 114000



G-SERIES

2-Sections 220-240/50/1V Export Refrigerator Reach-In
 Self-Contained Solid Door(s)



STANDARD PRODUCT FEATURES

- High Performance, Energy Efficient Refrigeration System
- Reliable Microprocessor Control With LED Temperature Display
- Evaporator Coil Outside Food Zone Provides More Usable Space
- Load-Sure Guard Prevents Problems From Improper Loading
- Durable All Metal Construction
- Stainless Steel Front & Doors, Anodized Aluminum Sides & Interior
- Full or Half Height Door Models with a Variety of Hinging Configurations
- Long Life EZ Clean Door Gaskets
- Three (3) Epoxy Coated Shelves Per Section (factory installed)
- Easy to Maintain Front Facing Condenser Coil
- 6" High Locking Casters
- Guaranteed for Life Door Handles & Hinges
- 1-Year Parts & Labor Warranty

ACCESSORIES & OPTIONS (*field installed)

- Tray Slides for 18" x 26" Sheet Pans*
- Tray Slides for 12" x 20" Food Pans*
- Tray Slides for 14" x 18" Sheet Pans*
- Tray Slides for 18" x 26, 12" x 20" & 14" x 18" Pans*
- Additional Shelves*
- 6" High Legs*
- Lower Height Casters*

*Please refer to form number TR35872 for precise kit details. See back page for tray slide versatility chart.

AVAILABLE CONFIGURATIONS

Half-Height Door Models G20100	Hinging Left/Right
Full-Height Door Models G20110	Hinging Left/Right

DEALERS CHOICE G-SERIES

SECTION 4-21

Approved by _____ Date _____ Approved by _____ Date _____



MODEL

Half Height Door Model: G20100

CLICK
TRANSFER
For KCL CADalog Website

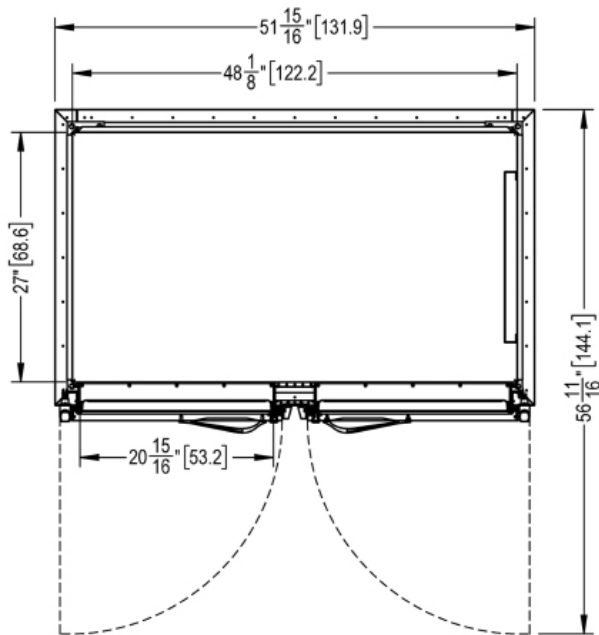
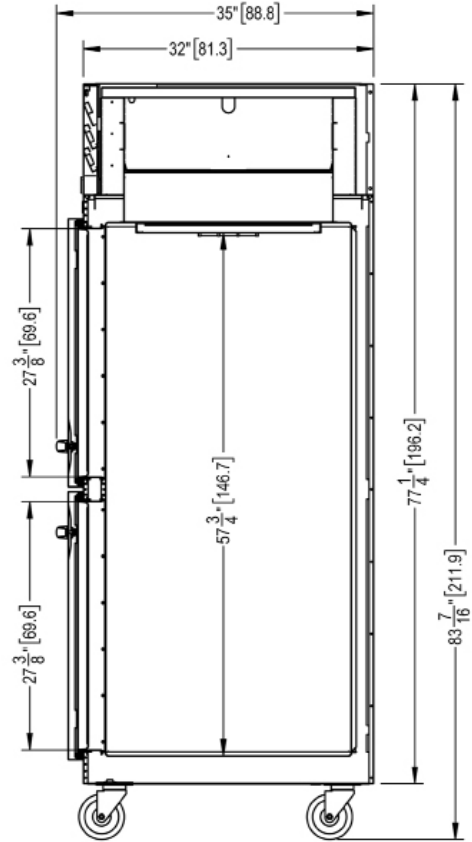
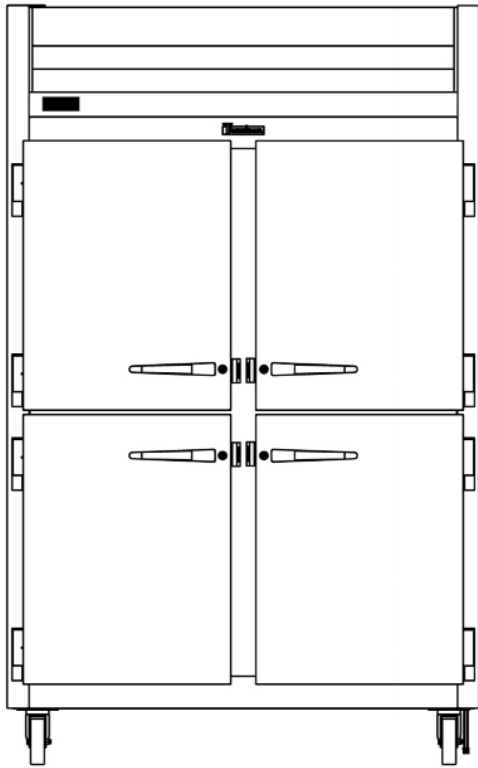

G-SERIES

2-Sections 220-240/50/1V Export Refrigerator

Reach-In

MODEL

Full Height Door Model: G20110

CLICK
TRANSFER
For KCL CADalog Website

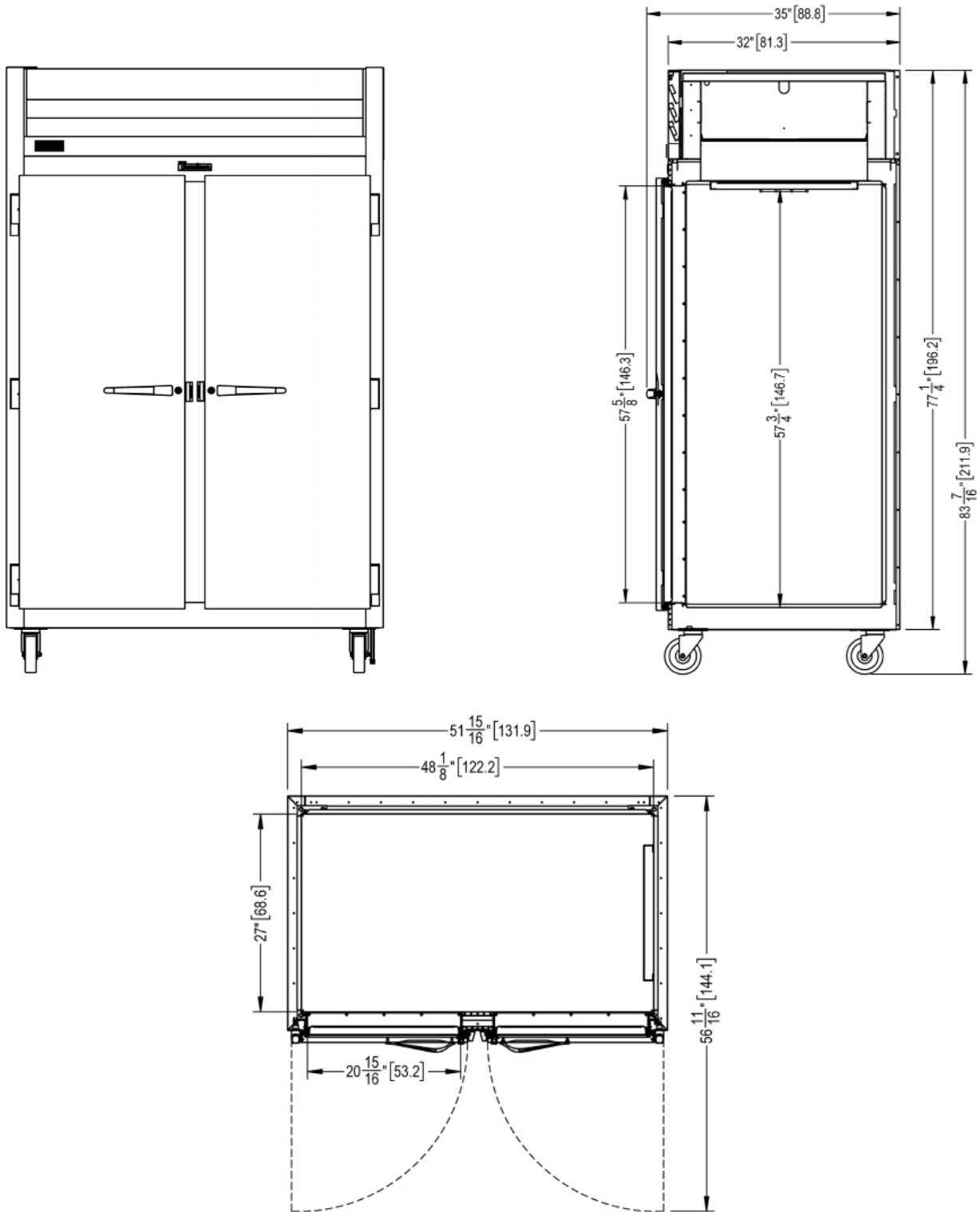

MODELS

Half Height Door Model: G20100

Full Height Door Model: G20110

MODELS	G201__
DIMENSIONAL DATA	
Net Capacity cu. ft. ¹	45.89 (1299 l) 46.02 (1303 l)
L x D x H - Overall in. ²	52½ (132.4 cm) x 35 (88.8 cm) x 83⅞ (211.9 cm)
Depth - over body in.	32 (81.3 cm)
Depth - door open 90° in.	57⅞ (146.3 cm)
Clear half-door W x H in.	21⅞ (53.6 cm) x 27½ (69.9 cm)
Clear full-door W X H in.	21⅞ (53.6 cm) x 57⅞ (146.3 cm)
No. Standard Shelves	6
Shelf Area sq. ft. ³	34.6 (3.21 sq m)
ELECTRICAL DATA	
Voltage Plug	220-240/50/1 n/a
Feed wires with ground	3
Minimum Circuit Breaker Amperes	15
Maximum Over Current Protection Amperes	15
REFRIGERATION DATA	
Refrigerant	R-134a
BTU/HR H.P. ⁴	2380 1/3 HP
Required Clearance	12" Above
SHIPPING DATA	
L x D x H Crated in.	62 (157 cm) x 42 (107 cm) x 85 (216 cm)
Volume Crated cu. ft.	128 (3625 l)
Uncrated Crated Weight lbs.	420 (191 kg) 480 (218 kg)

NOTES:

1. Net Capacity cu. ft. = Half Height Door | Full Height Door models.
2. Height shown when mounted on standard 6" high casters.
3. Figure shown reflects the area of standard shelf compliment.
4. Based on a 90°F (32.2 C) ambient and 20°F (-6.6 C) evaporator.

EQUIPMENT SPECIFICATIONS

CONSTRUCTION, HARDWARE, INSULATION

Cabinet exterior front, louver assembly and door(s) are constructed of 20 gauge stainless steel. Cabinet sides (including returns), interior and door liners are constructed of anodized aluminum. The exterior cabinet top, back and bottom are constructed of heavy gauge galvanized steel. A set of four (4) 6" high locking casters are included. Doors are equipped with a gasket protecting, raised metal door pan, cylinder locks, and guaranteed for life self-closing cam-lift hinges with a stay open feature at 120 degrees. Hinges include a concealed switch to automatically activate the interior LED lighting. Guaranteed for life, metal work flow door handles are mounted horizontally over recess in door which limits protrusion into aisle ways. Gasket profile and durable long life material simplify cleaning and increase overall gasket life. Anti condensate heaters are located behind each door opening. Both the cabinet and door(s) are insulated with an average of 2" thick high density, non-CFC, 100% foamed in place polyurethane.

SELF-CONTAINED REFRIGERATION SYSTEM

A top mounted, self-contained, balanced refrigeration system using R-134a refrigerant is conveniently located behind the one piece louver assembly. It features an easy to clean front facing condenser, thermostatic expansion valve metering device, air-cooled hermetic compressor, large, high humidity evaporator coil located outside the food zone and a top mounted non-electric condensate evaporator. Shipped with 9' cord without plug. Standard operating temperature is 34 to 38°F.

CONTROL

The easy to use water resistant microprocessor control is supplied standard. It includes a 3-Digit LED Display, and a Fahrenheit or Celsius Temperature Scale Display Capability.

INTERIOR ARRANGEMENTS

Standard interior arrangements include three (3) epoxy coated steel wire shelves per section, mounted on shelf pins, installed at the factory. Shelves are full-width, and do not have any large gaps between them requiring the use of "bridge" or "junior shelves." Recommended load limit per shelf should not exceed 225 lbs.

EXPORT WARRANTY

A one year parts and labor warranty is provided standard.

OPTIONAL ACCESSORY TRAY SLIDE VERSATILITY CHART

TRAY SLIDE DRAWINGS						
TRAY SLIDE OFFERING	#1 (1) 18" x26" or (2) 14"x18"	#4 (Rod Type) (1) 18" x26"	Universal (1) 18" x26" or (2) 14"x18" or (2) 12"x20"	#1 EZ-Change (1) 18" x26" or (2) 14"x18"	Universal EZ-Change (1) 18" x26" or (2) 14"x18" or (2) 12"x20"	HD Universal EZ-Change (1) 18" x26" or (2) 14"x18" or (2) 12"x20"
SPACING CAPACITY DOOR SIZE	2" 28 Pairs Full Door & 13 Half 3" 19 Pairs Full Door & 09 Half 4" 14 Pairs Full Door & 07 Half 5" 11 Pairs Full Door & 05 Half	1 1/2" 38 Pairs Full Door (2 Pair) 1 1/2" 18 Pairs Half Door (1 Pair)	4" 14 Pairs Full Door & 06 Half 4" 14 Pairs Full Door & 07 Half 5" 11 Pairs Full Door & 05 Half 6" 09 Pairs Full Door & 04 Half	2" 26 Pairs Full Door & 12 Half 4" 13 Pairs Full Door & 06 Half	2 1/4" 22 Pairs Full Door & 11 Half 4 1/2" 11 Pairs Full Door & 05 Half	4 1/2" 11 Pairs Full Door & 05 Half 9" 05 Pairs Full Door & 02 Half

- Upper Half Height Door¹
- Lower Half Height Door²

CONTINUED PRODUCT DEVELOPMENT MAY NECESSITATE SPECIFICATION CHANGES WITHOUT NOTICE.