



Project _____
 AIA # _____ SIS # _____
 Item # _____ Quantity _____ C.S.I. Section 114000



TBC-SERIES

Blast Chiller, Roll-In/Roll-Thru Self-Contained Maintenance System



STANDARD PRODUCT FEATURES

- High Performance Dual Refrigeration System (requires connection to an adequately sized remote condensing unit for blast chill operation)
- Easy to Use Touch Screen Control with Automatic or Manual Operation
- Adjustable Product Target Temps (40 to -5 degrees F) or Cycle Times
- Four Chill Settings: Blast Chill, Speed, Energy Saving & Delicate
- On-Board Cycle Data Printer
- Three (3) Removable Food Probes
- USB Port, 90-Day Cycle Data Memory
- Stainless Steel Exterior & Interior
- Long Life EZ Clean Door Gaskets
- Accommodates One (1) 27" W x 29" D x 72" H Roll-In Rack
- Easy to Maintain Front Facing Condenser Coil (maintenance system only)
- 3-Year Parts & Labor Warranty
- 2-Years Additional Compressor Parts Warranty

BLAST CHILLERS

SECTION 6-3



Intertek
4004142
Conforms to UL STD. 471
Cert. to CAN/CSA STD. C22.2 NO.120

This unit is listed to the applicable UL, CSA and NSF Standards by an approved NRTL. Consult the factory or unit's data plate for approval information.

ACCESSORIES & OPTIONS (*field installed)

- Label Printer (adds "-LP" to device number)
- Automatic Electric Condensate Evaporator (field installed)
- Special Roll-In Rack
- Air-Cooled Remote Condensing Unit
- Water-Cooled Remote Condensing Unit
- Combi Oven Compatibility Kit (accommodates racks with maximum dimensions of 31-1/2" W x 37-7/16" D x 72" H, increases overall cabinet depth to 44-1/2")

AVAILABLE CONFIGURATIONS

Device#	Hinging	Type	Other Feature
TBC1H-20	Left	Roll-In	No
TBC1H-24	Right	Roll-In	No
TBC1H-33	Right	Roll-In	Combi Oven Compatible
TBC1H-34	Left	Roll-In	Combi Oven Compatible
TBC1HR-1	FHL/RHL	Roll-Thru	No
TBC1HR-3	FHR/RHR	Roll-Thru	No

Approved by _____ Date _____ Approved by _____ Date _____



MODEL

TBC1H

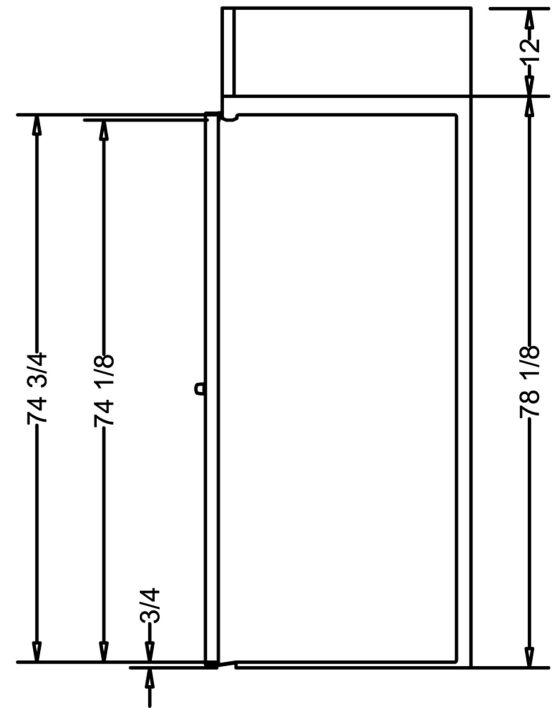
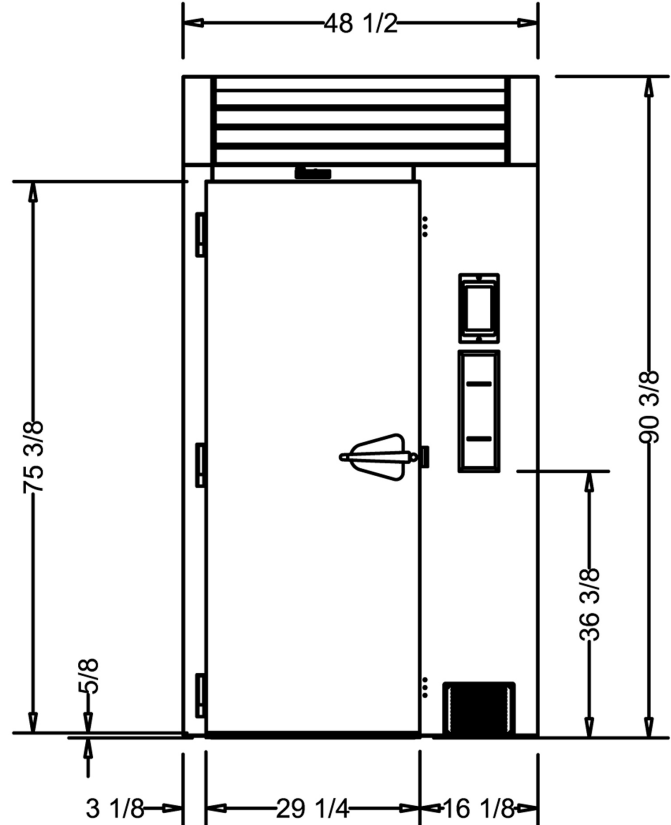
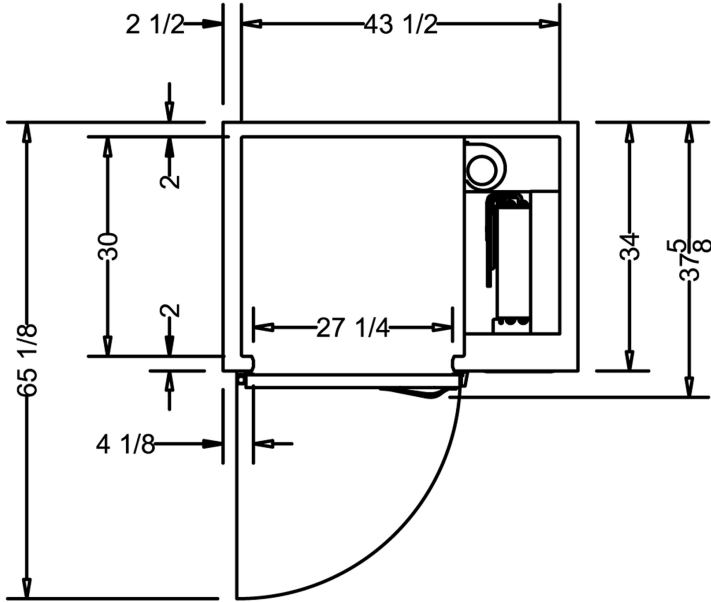

TBC-SERIES

Blast Chiller, Roll-In/Roll-Thru
Self-Contained Maintenance System

MODEL
TBC1HR

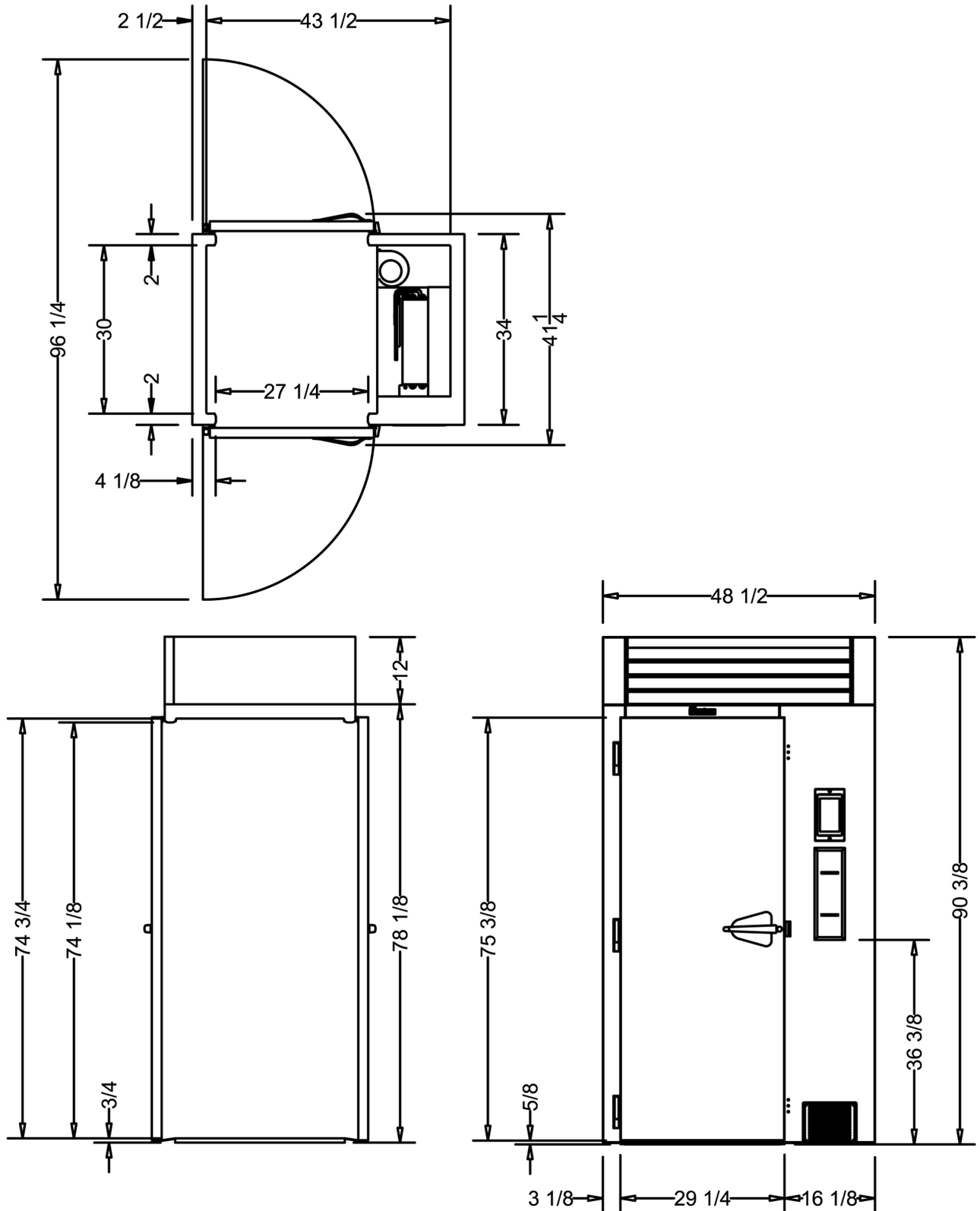



TBC-SERIES

Blast Chiller, Roll-In/Roll-Thru Self-Contained Maintenance System

MODEL

TBC1H & TBC1HR

MODELS	TBC1H TBC1HR
DIMENSIONAL DATA	
Net Capacity cu. ft.	35.0 (991 l)
L x D x H - Overall in.	48½ (123.2 cm) x 37¾ (95.5 cm) ¹ x 90¾ (229.6 cm)
Depth - over body in.	34 (86.4 cm)
Depth - door open 90° in.	65½ (165 cm) 96¼ (244 cm)
Clear door W x H in.	27¼ (69.3 cm) x 74¾ (188.3 cm)
Rack Capacity	1
Pan Capacity ²	[13] 18" x 26" [26] 12" x 20"
Product Capacity lbs.	300
ELECTRICAL DATA	
Voltage Plug	115/60/1 n/a
Feed wires with ground	4
Full Load Amps Req'd Circuit	16.0 20 Amp
REFRIGERATION DATA	
Refrigerant	R-404A
BTU/HR H.P. ² - Maintenance ³	2820 ½ HP
Recommended BTU/HR - Chill ⁴	18,700 ⁵
SHIPPING DATA	
L x D x H Crated in.	66 (167.6 cm) x 45 (114.3 cm) x 97 (246.3 cm)
Volume Crated cu. ft.	167 (4728.9 l)
Uncrated Crated Weight lbs.	775 (351.5 kg) 715 (324.3 kg)

NOTES:

1. Depth on roll-thru model TBC1HR is 41-1/4".
2. Rack capacities vary, estimated capacity shown.
3. Self-contained maintenance system only (Based on a 90°F ambient and 0°F evaporator).
4. Requires provision of a remote condensing unit for blast chill operation. Figure shown are recommended BTU's (using R-404A refrigerant) required at the evaporator.
5. Suction line and liquid line connections at blast chiller are 1/2".

ESTIMATED PERFORMANCE CHART

TBC1H/TBC1HR Product Load	Chill Time From 135°F to 40°F
200 (lbs.)	90
250 (lbs.)	120
300 (lbs.)	155

EQUIPMENT SPECIFICATIONS

CONSTRUCTION, HARDWARE, INSULATION

Cabinet exterior and interior are constructed of stainless steel. The exterior cabinet top, back and bottom are constructed of heavy gauge galvanized steel. The interior floor is constructed of stainless steel and insulated with 3/4" of resilient cork. Door is equipped with a cylinder lock and guaranteed for life self-closing cam-lift hinges with a stay open feature at 120 degrees. Gasket profile and durable long life material simplify cleaning and increase overall gasket life. Anti condensate heaters are located behind the door opening. Both the cabinet and door are insulated with an average of 2" thick high density, non-CFC, 100% foamed in place polyurethane.

SELF-CONTAINED REFRIGERATION SYSTEM

High-capacity, self-contained maintenance refrigeration system using R-404A refrigerant is coupled with an advanced air circulation system to rapidly chill hot food through the HACCP danger zone. It features a thermostatic expansion valve, high-humidity evaporator coil, high speed evaporator fans, air-cooled hermetic compressor, and hot gas defrost. A floor drain or optional condensate evaporator is required for condensate removal. The condenser coil is front facing for easy cleaning. Defrost occurs automatically, does not interrupt chill cycles in progress, nor starting new chill cycles, and intervals between defrost cycles are adjustable to better suit differing operational needs.

CONTROL / BASIC OPERATION

The easy to use touch screen control is water resistant and protected from damage by a heavy gauge stainless steel bezel. Using the three probes provided, it monitors cycle progress and records all HACCP required data. This information can then be printed at the end of the cycle using the on-board printer and/or retrieved later from memory, where it is stored for 90-days.

Chill cycles can be started in one of two ways using either the AUTO (touch free) or MANUAL (fully adjustable) operating mode. In AUTO mode, placing any probe in 90°F or above product will initiate a chill cycle using the default parameters (standard blast chill with a target temperature of 37°F) in approximately 30-seconds. In MANUAL mode, the operator can adjust all the cycle parameters to suit their needs. Upon pressing START the chill cycle will commence using these inputs. Failure to complete cycle programming in MANUAL mode will result in the chill cycle starting automatically in 5-minutes after the last button push (provided at least one probe had been placed in product 90°F or above).

Product and/or user names can be manually input at the beginning or end of the chill cycle if desired. Customized chill cycle parameters (i.e. chill recipes) can be loaded and stored in advance, by name.

Once a chill cycle is started, it will continue without interruption until either the target temperature (using probes) or time (without using probes) is met. When using the default target temperature of 37°F, rapidly circulating air will cycle between 10-14°F or as low as -25°F when the target temperature is set at -5°.

Upon cycle completion, the blast chiller will notify the operator with an audible alarm, and automatically revert to maintenance mode, holding the product at the target temperature until removed.

INTERIOR ARRANGEMENTS

Accommodates one roll-in rack with maximum dimensions (wheels inboard of frame) of 27" wide x 29" deep x 72" high. Racks are not supplied standard but are available as an optional accessory.

DOMESTIC WARRANTY

Both a three year parts and labor warranty and an additional two year compressor parts warranty (for a total of five) are provided standard.

CONTINUED PRODUCT DEVELOPMENT MAY NECESSITATE SPECIFICATION CHANGES WITHOUT NOTICE.