



TRUE MANUFACTURING CO., INC.
U.S.A. FOODSERVICE DIVISION

2001 East Terra Lane • O'Fallon, Missouri 63366-4434 • (636)240-2400
 Fax (636)272-2408 • Toll Free (800)325-6152 • Intl Fax# (001)636-272-7546
 Parts Dept. (800)424-TRUE • Parts Dept. Fax# (636)272-9471 • www.truemfg.com

Project Name: _____

Location: _____

Item #: _____ Qty: _____

Model #: _____

A/A #

SIS #

Model:
TPP-AT-67D-2-HC

Food Prep Table:

Solid Door & Drawers Pizza Prep Table with Alternate Top & Hydrocarbon Refrigerant



TPP-AT-67D-2-HC

- ▶ True's pizza prep tables are designed with enduring quality that protects your long term investment.
- ▶ Factory engineered, self-contained, capillary tube system using environmentally friendly R290 hydro carbon refrigerant that has zero (0) ozone depletion potential (ODP), & three (3) global warming potential (GWP).
- ▶ High capacity, factory balanced environmentally friendly forced-air refrigeration system holds 33°F to 41°F (.5°C to 5°C).
- ▶ NSF/ANSI Standard 7 compliant for open food product.
- ▶ All stainless steel front, top and ends. Corrosion resistant GalFan coated steel back.
- ▶ Interior - attractive, NSF approved, clear coated aluminum liner. Stainless steel floor with coved corners.
- ▶ Extra-deep 19½" (496 mm) full length removable cutting board included. Sanitary, high density, NSF approved white polyethylene provides tough preparation surface.
- ▶ Heavy duty, PVC coated wire shelves (door sections).
- ▶ Each drawer accommodates two (2) full size 12"L x 20"W x 8"D (305 mm x 508 mm x 204 mm) pans (sold separately).
- ▶ Foamed-in-place using a high density, polyurethane insulation that has zero ozone depletion potential (ODP) and zero global warming potential (GWP).

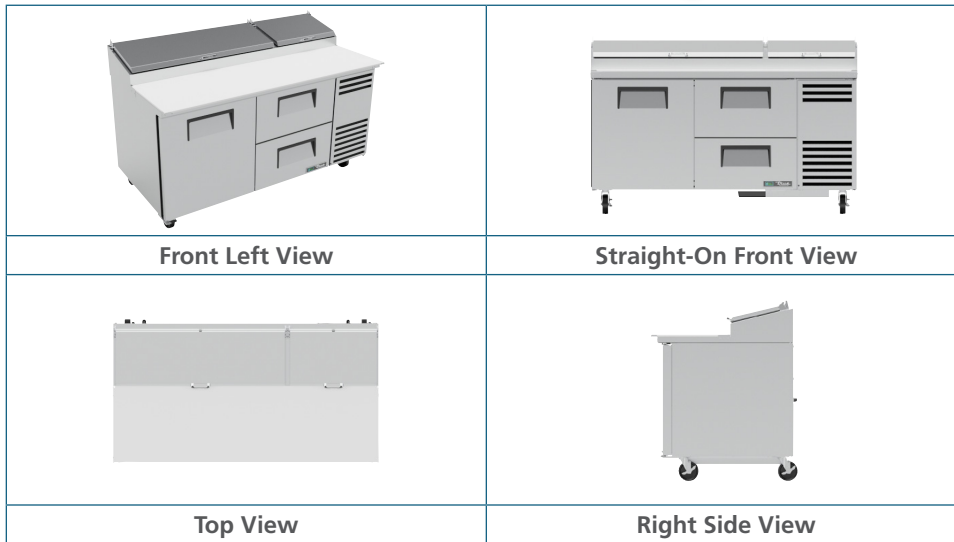

ROUGH-IN DATA

Specifications subject to change without notice.
 Chart dimensions rounded up to the nearest 1/8" (millimeters rounded up to next whole number).

Model	Doors	Drawers	Shelves	Pans (top)	Cabinet Dimensions (inches) (mm)			HP	Voltage	Amps	NEMA Config.	Cord Length (total ft.) (total m)	Crated Weight (lbs.) (kg)
					W	D†	H*						
TPP-AT-67D-2-HC	1	2	2	9	67¾ 1711	33¾ 854	38¾ 987	¼ ¼	115/60/1 230-240/50/1	3.9 1.8	5-15P ▲	11 3.35	TBD —

† Depth does not include 1" (26 mm) for rear bumpers and 1¾" (44 mm) for cutting board.

* Height does not include 5¾" (146 mm) for castors or 6" (153 mm) for optional legs.

▲ Plug type varies by country.



APPROVALS:

AVAILABLE AT:

Model:
TPP-AT-67D-2-HC

Food Prep Table:
*Solid Door & Drawers Pizza Prep Table with
Alternate Top & Hydrocarbon Refrigerant*



STANDARD FEATURES

DESIGN

- True's commitment to using the highest quality materials and oversized refrigeration systems provides the user with colder product temperatures, lower utility costs, exceptional food safety and the best value in today's food service marketplace.

REFRIGERATION SYSTEM

- Factory engineered, self-contained, capillary tube system using environmentally friendly R290 hydrocarbon refrigerant that has zero (0) ozone depletion potential (ODP), & three (3) global warming potential (GWP).
- High capacity, factory balanced refrigeration system with guided airflow to provide uniform temperature in food pan rail and cabinet interior.
- Forced-air design holds 33°F to 41°F (.5°C to 5°C) product temperature in food pans and cabinet interior. Complies with ANSI/NSF-7.
- Condensing unit accessed from behind front removable panel, slides out for easy maintenance.

CABINET CONSTRUCTION

- All stainless steel front, top and ends. Corrosion resistant GalFan coated steel back.
- Stainless steel, patented, foam insulated flat lids keep pan temperatures colder, lock in freshness, and minimize condensation.
- Interior - attractive, NSF approved, clear coated aluminum liner. Stainless steel floor with coved corners.
- Insulation - entire cabinet structure, solid doors, and drawer facings are foamed-in-place using a high density, polyurethane insulation that has zero ozone depletion potential (ODP) and zero global warming potential (GWP).
- 5" (127 mm) diameter stem castors. 36" (915 mm) work surface height.

DOOR / DRAWERS

- Door or drawer assemblies can be located in any section of the cabinet. Location of door/drawers must be indicated at time of ordering.
- Door constructed of stainless steel exterior with white aluminum liner to match cabinet interior. Drawers have stainless steel exterior facings and liners with stainless steel frames.
- Each door and drawer fitted with 12" (305 mm) long recessed handle that is foamed-in-place with a sheet metal interlock to ensure permanent attachment.
- Positive seal door swings within cabinet dimensions.
- Magnetic door/drawer gaskets of one piece construction, removable without tools for ease of cleaning.
- Heavy-duty stainless steel drawer slides and rollers. Removable without tools for easy cleaning.
- Each drawer accommodates two (2) full size 12"L x 20"W x 8"D (305 mm x 508 mm x 204 mm) food pans (sold separately). Drawer will support varying pan configurations with pan dividers bars (drawer pans and divider bars optional).

SHELVING

- Four (4) adjustable, heavy duty PVC coated wire shelves 23 5/8"L x 28"D (601 mm x 712 mm). Four (4) chrome plated shelf clips included per shelf.
- Shelf support pilasters made of same material as cabinet interior; shelves are adjustable on 1/2" (13 mm) increments.

MODEL FEATURES

- Evaporator is epoxy coated to eliminate the potential of corrosion.
- Extra-deep 19 1/2" (496 mm), full length removable cutting board included. Sanitary, high-density, NSF approved white polyethylene provides tough preparation surface.

- Alternate top 13° pan angle. Stainless steel, patented, foam insulated lids keep pan temperatures colder, lock in freshness, and minimize condensation.
- Refrigerated pan rail comes standard with nine (1/2 size) 12 3/4"L x 6 1/4"W x 6"D (324 mm x 159 mm x 153 mm) NSF approved clear polycarbonate insert pans.
- Front discharge design.
- NSF/ANSI Standard 7 compliant for open food product.

ELECTRICAL

- Unit completely pre-wired at factory and ready for final connection to a 115/60/1 phase, 15 amp dedicated outlet. Cord and plug set included.



115/60/1
NEMA-5-15R

OPTIONAL FEATURES/ACCESSORIES

Upcharge and lead times may apply.

- 230 - 240V / 50 Hz.
- 6" (153 mm) standard legs.
- 6" (153 mm) seismic/flanged legs.
- 4" (102 mm) diameter castors.
- 3" (85 mm) diameter castors.
- 2 1/2" (64 mm) diameter castors.
- Barrel lock available for door section (factory installed).
- Garnish rack.
- Single overshelf.
- Double overshelf.
- Half bun tray rack (door section only). Holds up to eleven 18"L x 26"D (458 mm x 661 mm) sheet pans (sold separately).
- 19 1/2" (496 mm) deep, 1/2" (13 mm) thick, composite cutting board.
- Pan dividers.
- Exterior round digital temperature display (factory installed).

PLAN VIEW

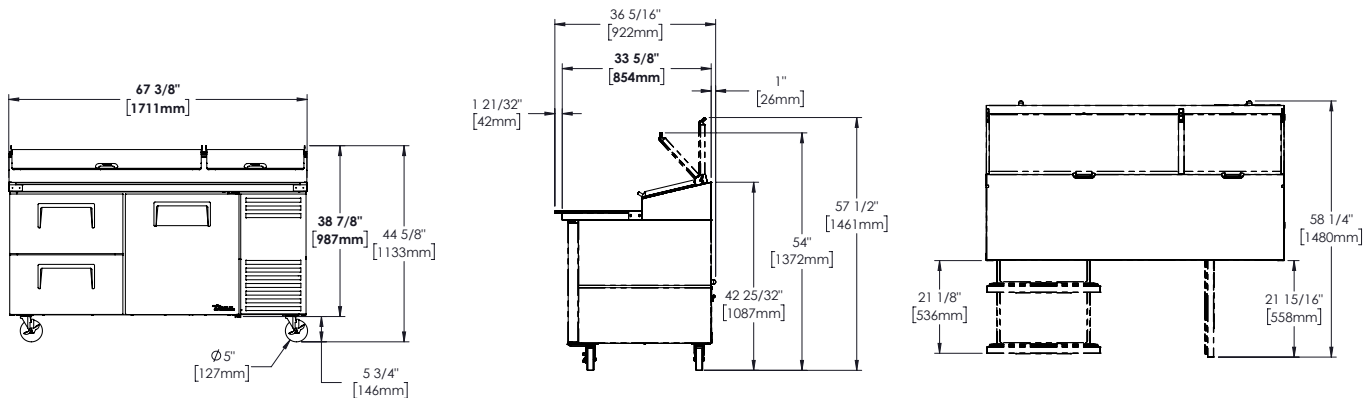

WARRANTY

Three year warranty on all parts and labor and an additional 2 year warranty on compressor. (U.S.A. only)

METRIC DIMENSIONS ROUNDED UP TO THE NEAREST WHOLE MILLIMETER

SPECIFICATIONS SUBJECT TO CHANGE WITHOUT NOTICE



Model	Elevation	Right	Plan	3D	Back
TPP-AT-67D-2-HC					

TRUE MANUFACTURING CO., INC.

2001 East Terra Lane • O'Fallon, Missouri 63366-4434 • (636)240-2400 • Fax (636)272-2408 • Toll Free (800)325-6152 • Intl. Fax# (001)636-272-7546 • www.truefmfg.com