



TRUE FOOD SERVICE EQUIPMENT, INC.

2001 East Terra Lane • O'Fallon, Missouri 63366-4434 • (636)240-2400
 Fax (636)272-2408 • Toll Free (800)325-6152 • Intl Fax# (001)636-272-7546
 Parts Dept. (800)424-TRUE • Parts Dept. Fax# (636)272-9471 • www.truemfg.com

Project Name: _____

Location: _____

Item #: _____ Qty: _____

Model #: _____

A/A #

SIS #

Model:

TSSU-60-16-ADA-HC

Food Prep Table:

ADA Compliant Solid Door Sandwich/Salad Unit with Hydrocarbon Refrigerant



TSSU-60-16-ADA-HC

- ▶ 3" (77 mm) diameter stem castors standard. Work surface 34" (864 mm) high to comply with the Americans with Disabilities Act (ADA) requirements.
- ▶ Factory engineered, self-contained, capillary tube system using environmentally friendly R290 hydrocarbon refrigerant that has zero (0) ozone depletion potential (ODP), & three (3) global warming potential (GWP).
- ▶ Patented forced-air design holds 33°F to 41°F (.5°C to 5°C) product temperature in food pans and cabinet interior.
- ▶ Complies with ANSI/NSF-7.
- ▶ Exterior - stainless steel front, top and ends. Corrosion resistant GalFan coated steel back.
- ▶ Stainless steel, patented, foam insulated lid and hood keep pan temperatures colder, lock in freshness and minimize condensation. Removable for easy cleaning.
- ▶ Interior - attractive, NSF approved, clear coated aluminum liner. Stainless steel floor with coved corners.
- ▶ 11 ¾" (299 mm) deep full length removable cutting board included. Sanitary, high density, NSF approved white polyethylene provides tough preparation surface.
- ▶ Heavy duty PVC coated wire shelves.
- ▶ Foamed-in-place using a high density, polyurethane insulation that has zero ozone depletion potential (ODP) and zero global warming potential (GWP).

ROUGH-IN DATA

Specifications subject to change without notice. Chart dimensions rounded up to the nearest 1/8" (millimeters rounded up to next whole number).

Model	Doors	Shelves	Pans (top)	Cabinet Dimensions (inches) (mm)			HP	Voltage	Amps	NEMA Config.	Cord Length (total ft.) (total m)	Crated Weight (lbs.) (kg)
				W	D†	H*						
TSSU-60-16-ADA-HC	2	4	16	60¾ 1534	30⅞ 766	36¾ 934	1/8 N/A	115/60/1	6.5 N/A	5-15P	7 2.13	360 164

† Depth does not include 1" (26 mm) for rear bumpers.

* Height does not include 4" (1102 mm) for castors.

1/17 Printed in U.S.A.

APPROVALS:

AVAILABLE AT:

Model:
TSSU-60-16-ADA-HC

Food Prep Table:
*ADA Compliant Solid Door Sandwich/Salad Unit
with Hydrocarbon Refrigerant*



STANDARD FEATURES

DESIGN

- True's salad/sandwich units are designed with enduring quality that protects your long term investment.
- True's commitment to using the highest quality materials and oversized refrigeration systems provides the user with colder product temperatures, lower utility costs, exceptional food safety and the best value in today's food service marketplace.

REFRIGERATION SYSTEM

- Factory engineered, self-contained, capillary tube system using environmentally friendly R290 hydrocarbon refrigerant that has zero (0) ozone depletion potential (ODP), & three (3) global warming potential (GWP).
- Energy efficient, factory balanced refrigeration system with guided airflow to provide uniform temperature in food pans and cabinet interior.
- Patented forced-air design holds 33°F to 41°F (5°C to 5°C) product temperature in food pans and cabinet interior. Complies with ANSI/NSF-7.
- Sealed, self-lubricating evaporator fan motor and larger fan blades give True sandwich/salad units a more efficient, low velocity, high volume airflow design.
- Condensing unit access in back of cabinet, slides out for easy maintenance.

CABINET CONSTRUCTION

- Exterior - stainless steel front, top and ends. Corrosion resistant GalFan coated steel back.
- Interior - attractive, NSF approved, clear coated aluminum liner. Stainless steel floor with coved corners.
- Insulation - entire cabinet structure and solid doors are foamed-in-place using a high density, polyurethane insulation that has zero ozone depletion potential (ODP) and zero global warming potential (GWP).
- 3" (77 mm) diameter stem castors. 34" (864 mm) work surface height.

DOORS

- Stainless steel exterior with clear aluminum liner to match cabinet interior.
- Each door fitted with 12" (305 mm) long recessed handle that is foamed-in-place with a sheet metal interlock to ensure permanent attachment.
- Positive seal self-closing doors with 90° stay open feature. Doors swing within cabinet dimensions.
- Magnetic door gaskets of one piece construction, removable without tools for ease of cleaning.

SHELVING

- Four (4) adjustable, heavy duty PVC coated wire shelves 27 1/2" L x 16"D (699 mm x 407 mm). Four (4) chrome plated shelf clips included per shelf.
- Shelf support pilasters made of same material as cabinet interior; shelves are adjustable on 1/2" (13 mm) increments.

DRAWER PAN CAPACITY

- Comes standard with 16 (1/8 size) 6 7/8" L x 6 1/4" W x 4"D (175 mm x 159 mm x 102 mm) clear polycarbonate, NSF approved, food pans in countertop prep area. Also accommodates 6" (153 mm) deep food pans (supplied by others).
- Countertop pan opening designed to fit varying size pan configurations with available pan divider bars. Pans supplied by others.

MODEL FEATURES

- Evaporator is epoxy coated to eliminate the potential of corrosion.
- 11 3/4" (299 mm) deep full length removable cutting board included. Sanitary, high-density, NSF approved white polyethylene provides tough preparation surface.
- Stainless steel, patented, foam insulated lid and hood keep pan temperatures colder, lock in freshness and minimize condensation. Removable for easy cleaning.
- NSF/ANSI Standard 7 compliant for open food product.

ELECTRICAL

- Unit completely pre-wired at factory and ready for final connection to a 115/60/1 phase, 15 amp dedicated outlet. Cord and plug set included.



115/60/1
NEMA-5-15R

OPTIONAL FEATURES/ACCESSORIES

Upcharge and lead times may apply.

- Barrel locks (factory installed). Requires one per door.
- Additional shelves.
- Single overshef.
- Double overshef.
- Flat lids.
- Sneezeguard.
- 19" (483 mm) deep, 1/2" (13 mm) thick, white polyethylene cutting board. Requires "L" brackets.
- 19" (483 mm) deep, 3/4" (20 mm) thick, white polyethylene cutting board. Requires "L" brackets.
- 11 3/4" (299 mm) deep, 1/2" (13 mm) thick, composite cutting board. Requires "L" brackets.
- 19" (483 mm) deep, 1/2" (13 mm) thick, composite cutting board. Requires "L" brackets.
- Crumb catcher. Requires crumb catcher cutting board for proper installation.
- Pan dividers.
- Exterior rectangular digital thermometer (factory installed).
- Standard height unit with 5" (127 mm) diameter castors. 36" (915 mm) work surface height.

PLAN VIEW

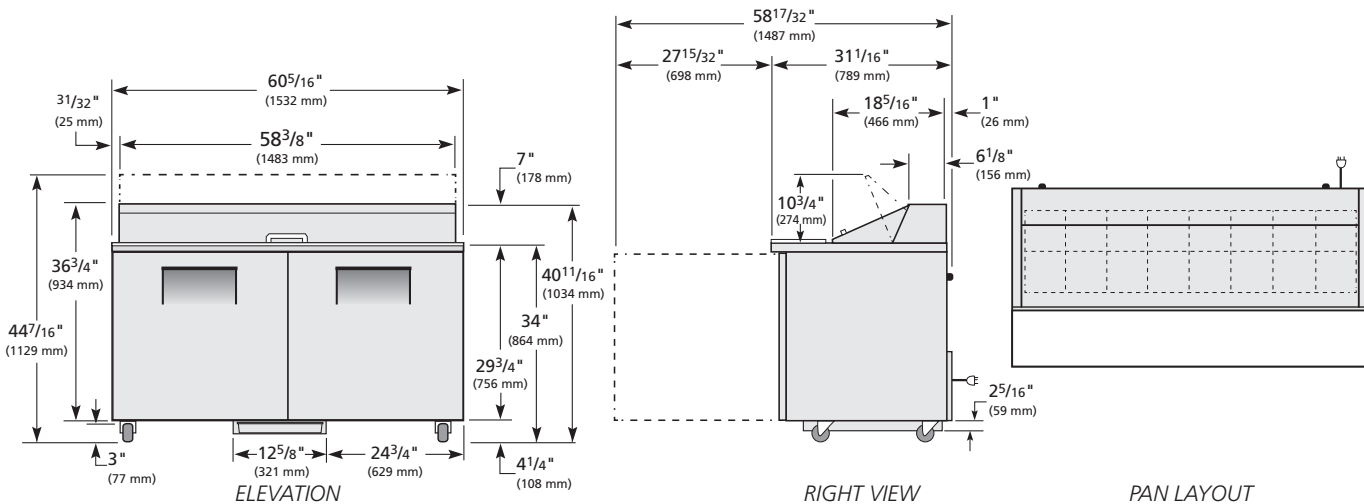

WARRANTY*
Three year warranty on all parts and labor and an additional 2 year warranty on compressor. (U.S.A. only)

METRIC DIMENSIONS ROUNDED UP TO THE NEAREST WHOLE MILLIMETER

SPECIFICATIONS SUBJECT TO CHANGE WITHOUT NOTICE



Model	Elevation	Right	Plan	3D	Back
TSSU-60-16-ADA-HC					

TRUE FOOD SERVICE EQUIPMENT